

KENWOOD

KR-1000 KR-1000B

AM-FM STEREO RECEIVER

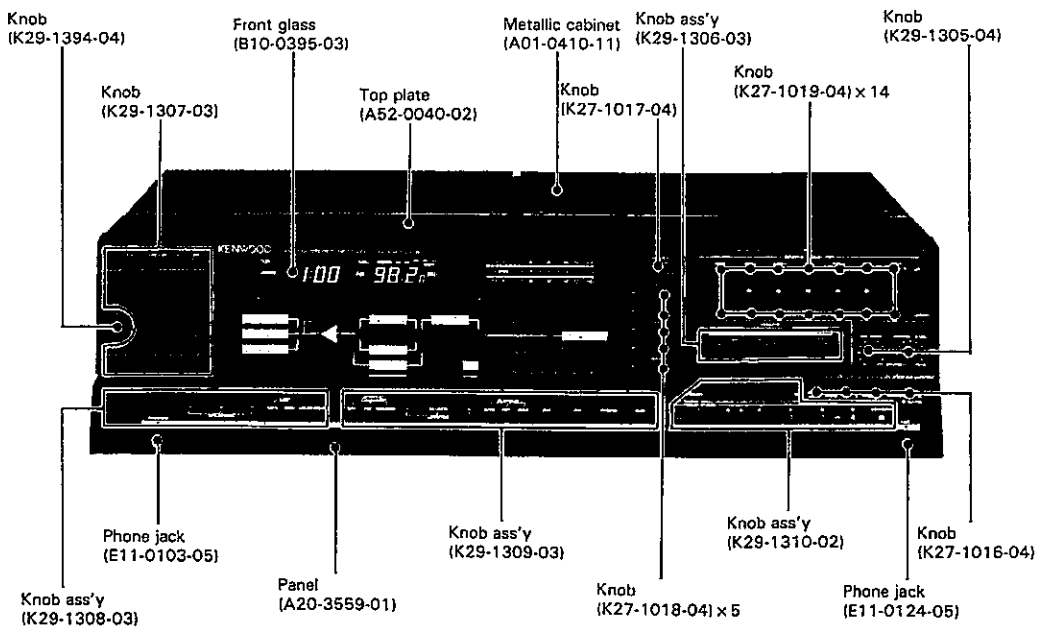
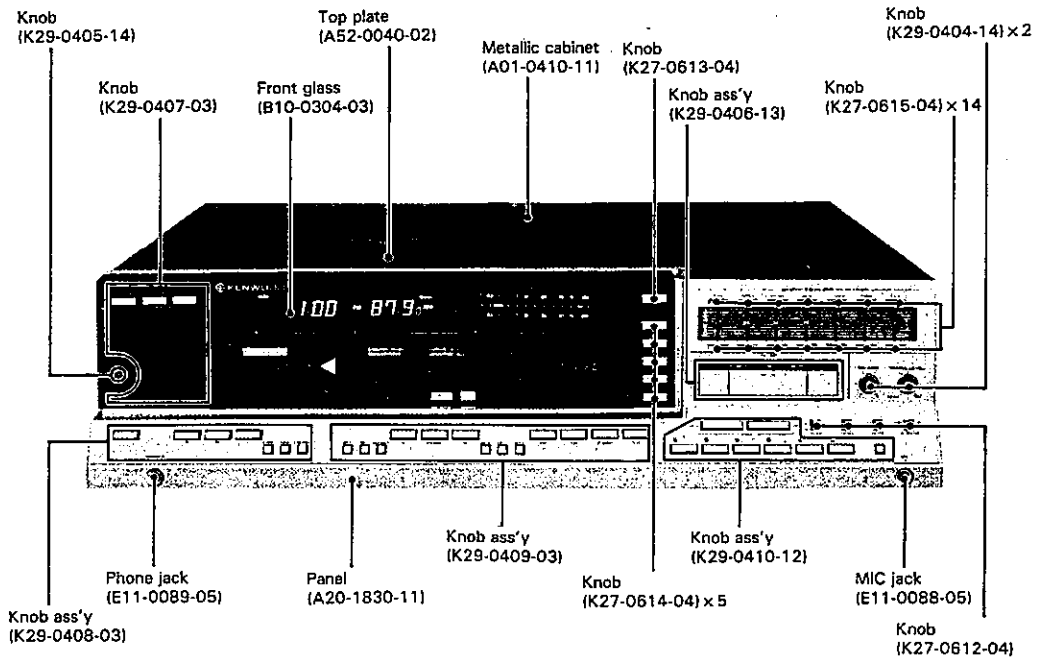

EXTERNAL VIEW/DIAL CORD STRINGING

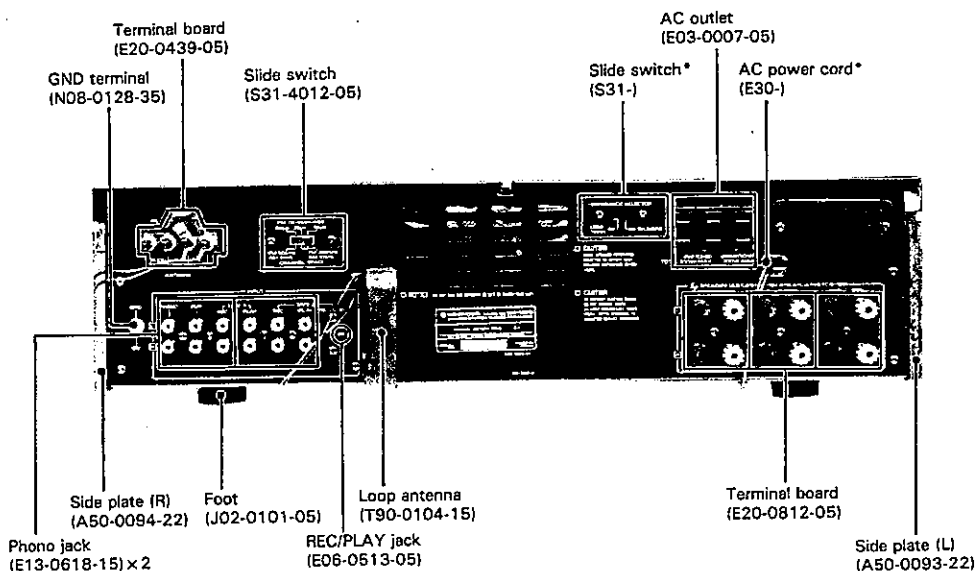

*Refer to parts list on page 40.

DIAL CORD STRINGING

1. Attach the dial cord to the dial spring and proceed from ① to ③.
2. Wind the dial string twice around the motor pulley ④ and proceed from ⑤ to ⑦.
3. Turn the pulley fully clockwise and slide the belt so that the boundary between black and white moves to the tip of the arrow. ⑧ Fix the hardware to the dial cord with an adhesive. ⑨

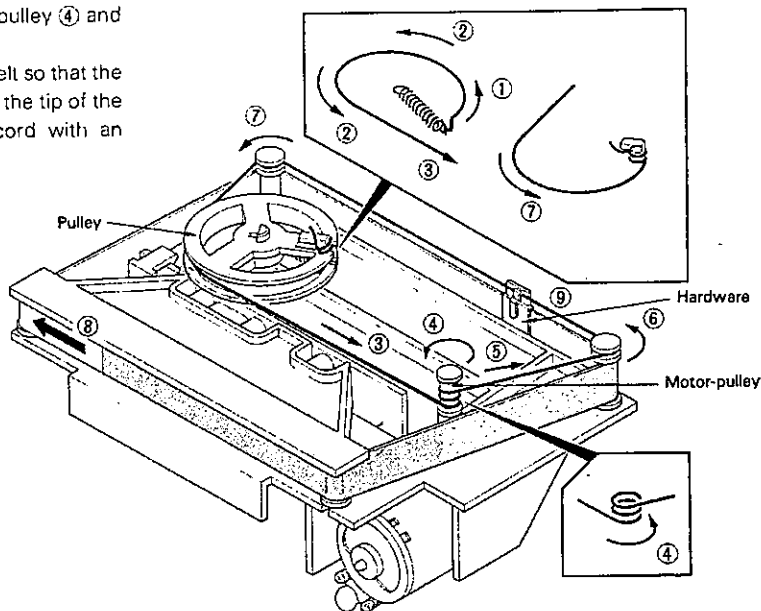
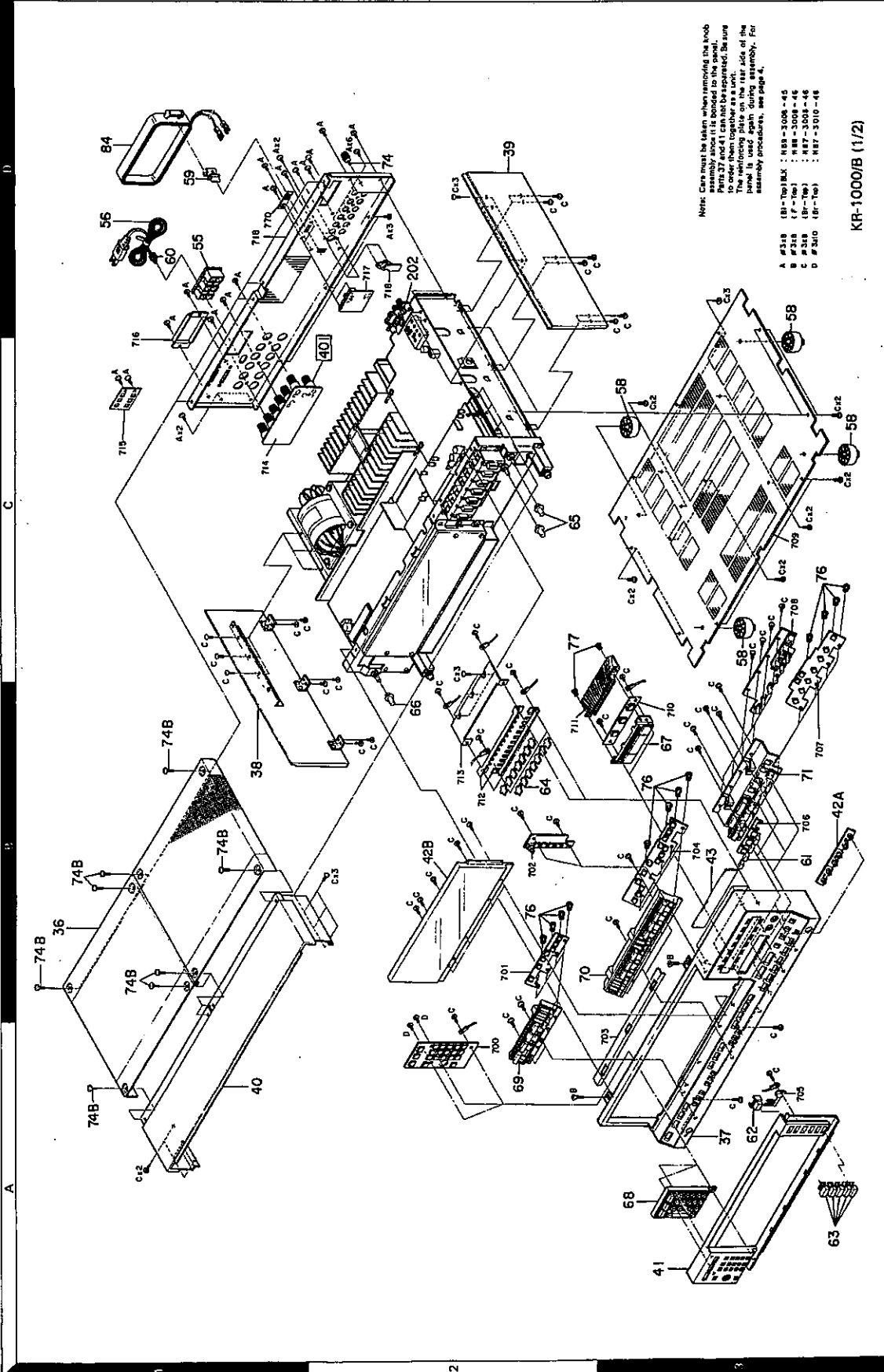

Fig. 1 Dial Cord Stringing

KR-1000/B KR-1000/B

EXPLODED VIEW

Parts of small exploded view Nos. are not supplied



Note: Care must be taken when removing the knob assembly since it is bonded to the panel. Parts 37 and 41 can not be separated. Be sure to use the wiring plate on the rear side of the panel. It used again during assembly. For assembly procedures, see page 4.

- A #518 (B-Ten) 1X : 187-3008-45
- B #314 (B-Ten) 1X : 187-3008-46
- C #338 (B-Ten) 1X : 187-3008-48
- D #310 (B-Ten) 1X : 187-3010-48

KR-1000/B (1/2)

KR-1000/B KR-1000/B

EXPLODED VIEW

Parts of small exploded view Nos. are not supplied

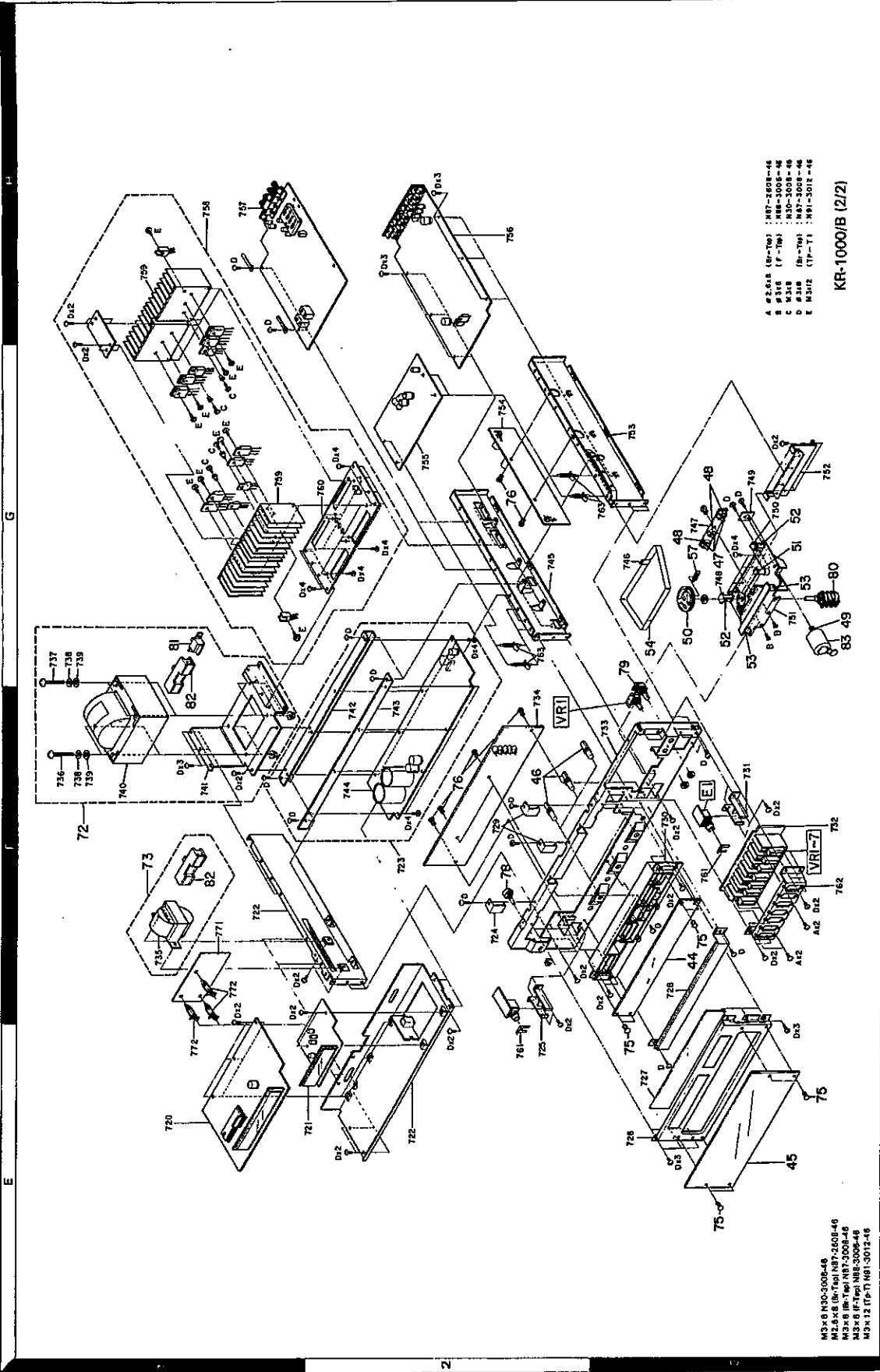

- A D 2 x 6 (R-702) : M2-2008-46
- B 3/16 (F-704) : M2-2008-46
- C M 3/16 (R-704) : M30-2008-46
- D #318 (R-704) : M27-2008-46
- E M3/12 (TP-1) : M91-3012-46

KR-1000/B (2/2)

- M3 x 6 M30-2008-46
- M2 x 6 (R-702) M2-2008-46
- M3 x 6 (R-704) M30-2008-46
- M3 x 6 (F-704) M27-2008-46
- M3 x 12 (TP-1) M91-3012-46

Refer to parts list on page 40.

PANEL ASSEMBLY/DISASSEMBLY FOR REPAIR

- (1) Affix double-sided adhesive tape to the left side of the panel escutcheon. (1)
- (2) Hook the claws on the panel into the holes on the bottom side of the panel escutcheon. (2)
- (3) Stand the panel escutcheon so that the gap between the top side of the panel and panel escutcheon is uniform. (3)
- (4) Keeping the gap even, shift the panel escutcheon in the direction indicated by arrow (4) so that the panel and panel escutcheon are bonded by the tape.
- (5) Affix double-sided adhesive tape to the mounting hardware and apply the mounting hardware to the panel and panel escutcheon. Apply adhesive to the dotted parts. (5)

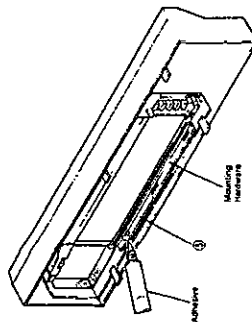
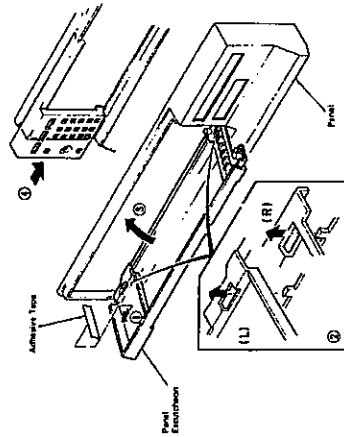

DISASSEMBLY FOR REPAIR

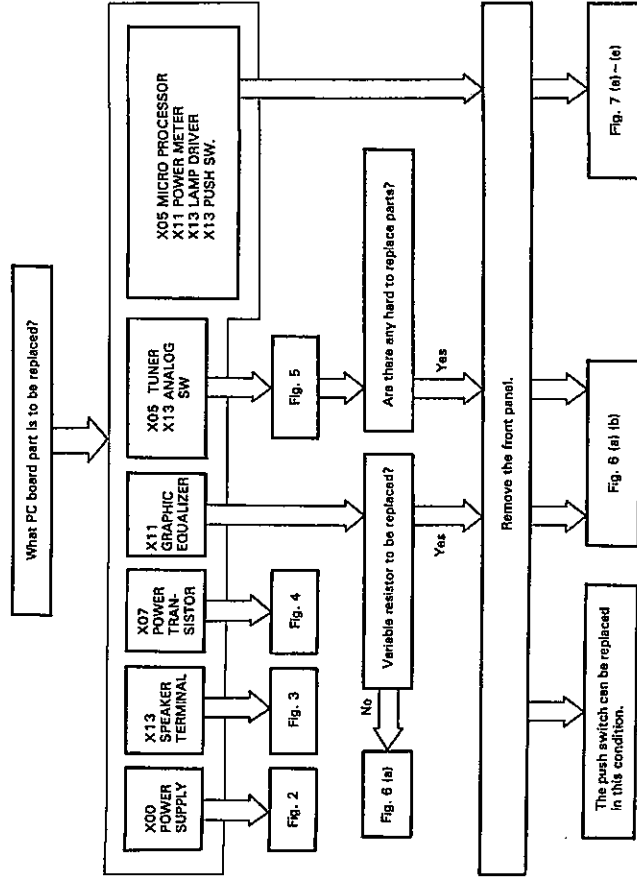

1. Removing the Power Supply PC Board (X00)

- (1) Remove the bottom plate.
- (2) Loosen 8 screws holding the PC board, disconnect wires which restrict movement of the PC board and pull it out.
- (3) Turn the PC board as shown by the arrow in the figure at the right. Now parts can be replaced.

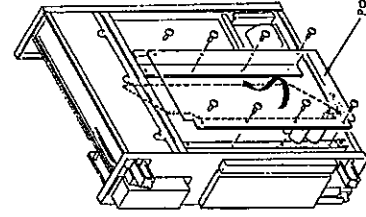

Fig. 2

DISASSEMBLY FOR REPAIR

- For disassembly for repair, follow the disassembly instructions in the figure for the location to be replaced as indicated in the figure on the next page.

Note:

1. When connectors and leads are disconnected from PC boards for disassembly, be extremely careful to ensure that they are reconnected in their original positions.
2. During reassembly, be extremely careful to ensure that the leads are reconnected in the same shape they were in prior to disassembly; failure to do so may result in performance degradation or inability to complete reassembly.

3. When replacing the panel, refer to the panel assembly procedure on this page for assembly since the front panel and panel escutcheon are delivered separately as repair parts.

DISASSEMBLY FOR REPAIR

2. Removing the Speaker Terminal Board

- (1) Remove the 6 screws holding the rear panel. The rear panel is not removed at this point because it is connected to the antenna terminal and phono jack boards.
- (2) Remove the 3 screws fixing the speaker terminal to the rear panel.
- (3) Pull the rear panel slightly in the direction indicated by arrow ① and pull out the SP terminal in the direction indicated by arrow ②.

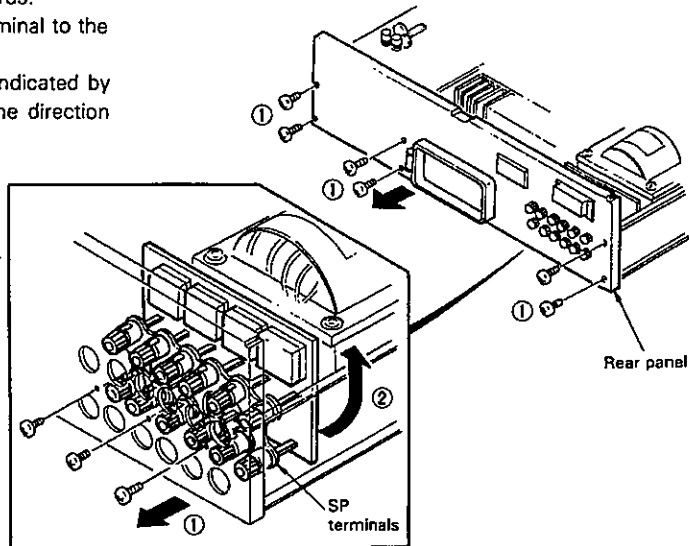

Fig. 3

3. Power Transistor Replacement

- (1) Remove the PC board which holds the heat sink from above. (①)
- (2) When one of the transistors on a heat sink without a varistor is defective, unsolder the terminals of all transistors mounted on that heat sink. Then remove the screws holding the heat sink to the PC board from the bottom side, remove the heat sink and transistors together and replace the transistors.
- (3) When one of the transistors on the heat sink with a varistor is defective, remove the PC board together with the four heat sink mounted on it and loosen the screw holding the varistor to the heat sink. Then replace the transistor as described at right.

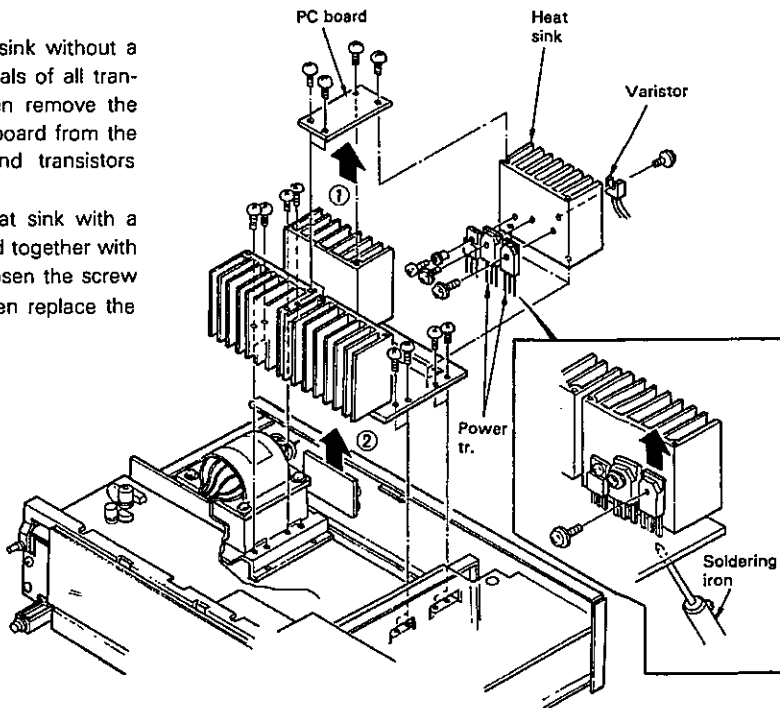

Fig. 4

DISASSEMBLY FOR REPAIR

4. Removing the Tuner Unit (X05)

- (1) Loosen the 5 screws holding the side plate. (①)
- (2) Loosen the 4 screws holding the tuner unit and remove it in the direction indicated by arrow ②.

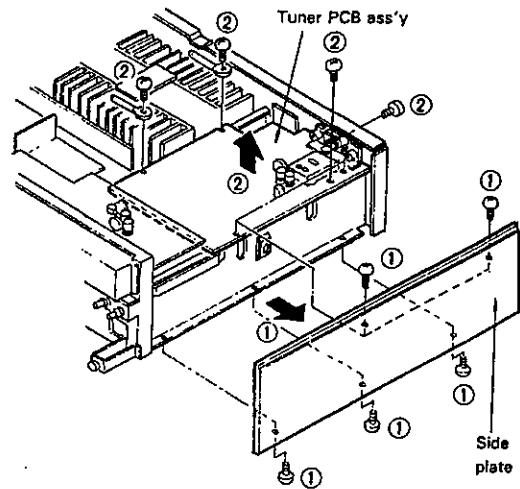

Fig. 5

5. Removing the Graphic Equalizer PC Boards

- (1) Remove the PC boards from the 4 PC board holders. (①)
- (2) Loosen the 4 screws holding the PC board on which a variable resistor is mounted and remove it from the sub-panel. (②)

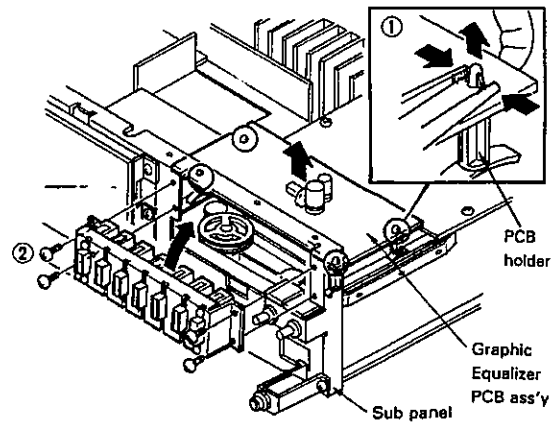

Fig. 6 (a)

6. Removing the Volume Reflector

- (1) Remove the 2 screws holding the volume reflector to the sub panel.
- (2) Remove the 2 screws holding the volume reflector to the frame.

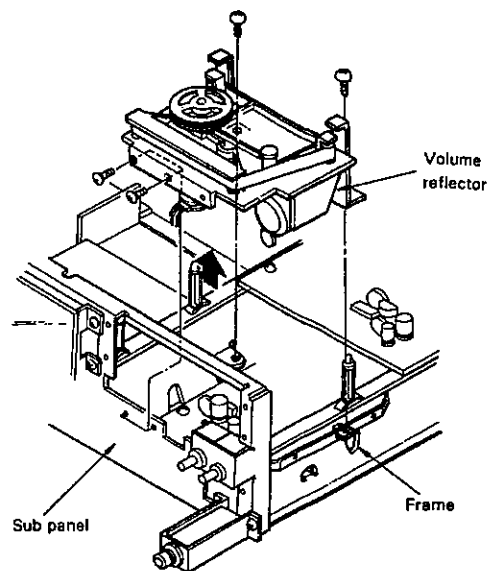
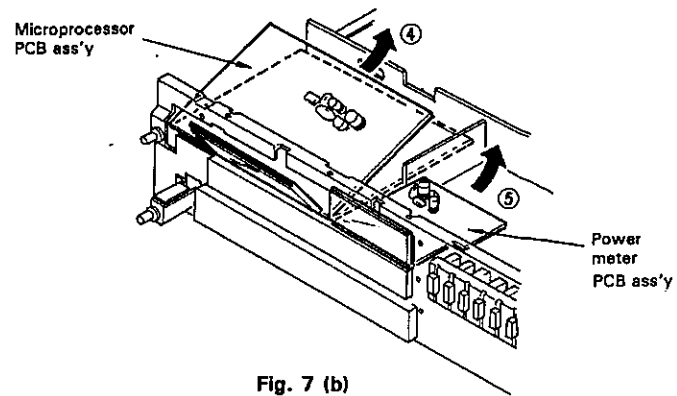
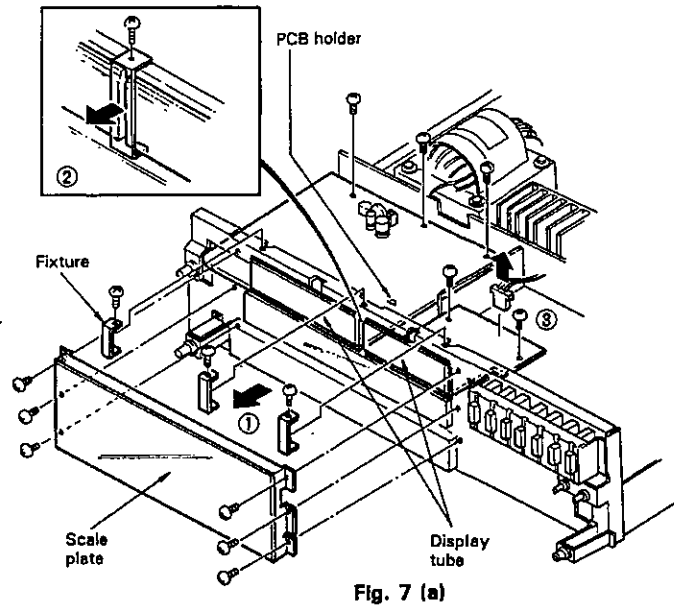

Fig. 6 (b)

DISASSEMBLY FOR REPAIR

7. Removing the Microprocessor PC Board and Power Meter PC Board

- (1) Remove the front panel.
- (2) Remove the 6 screws holding the scale plate.
- (3) Remove the 3 screws holding the fixtures for the fluorescent display tubes. (①, ②)
- (4) Remove the screws holding the PC boards to the frame. (There is one PC board holder on the X05 PC board.)
- (5) Tilt the PC boards in the direction indicated by the arrows ④ ⑤ and pull them out, being careful not to damage the fluorescent display tubes.



8. Lamp Replacement

- (1) Remove the push rivets holding the dial plate. Use a standard screwdriver or other tool with a sharp tip to pop out the push rivets.
- (2) Use long nose pliers to grasp the rubber portion of the lamp and pull it out.

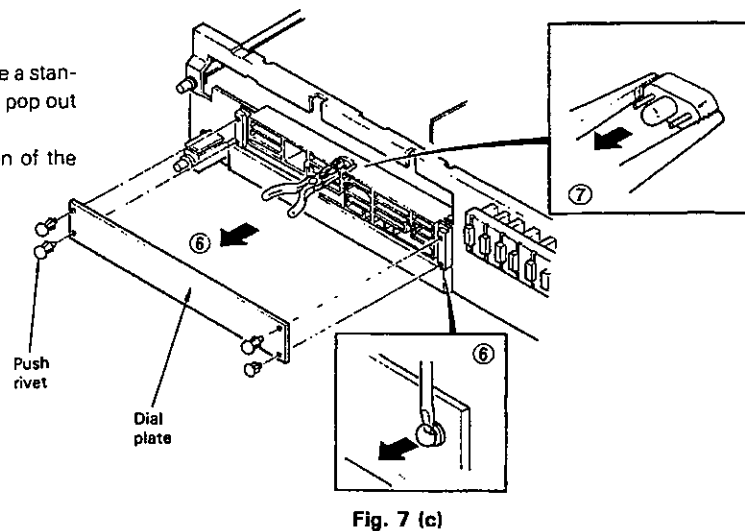

DISASSEMBLY FOR REPAIR

9. Removing the Lamp Driver PC Board

- (1) Remove the graphic equalizer PC board. (⑧)
- (2) Remove the PC boards on which fluorescent display tubes are mounted. (⑨, ⑩)
- (3) Remove the 4 screws holding the frame on which the fluorescent display tubes were fastened and slide it to the rear. (⑪)
- (4) Remove the 4 push rivets holding the lamp driver PC board. (⑫) Then remove the 4 screws holding the reflector and remove it.
- (5) Pull the lamp driver PC board out from the top. (⑬)

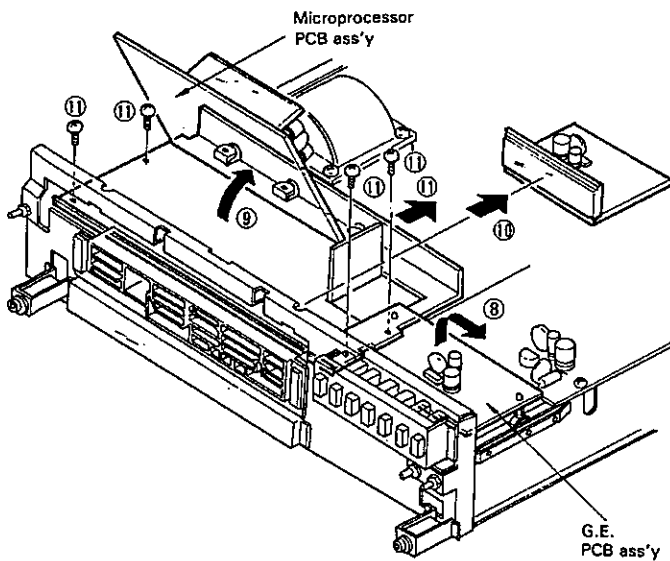

Fig. 7 (d)

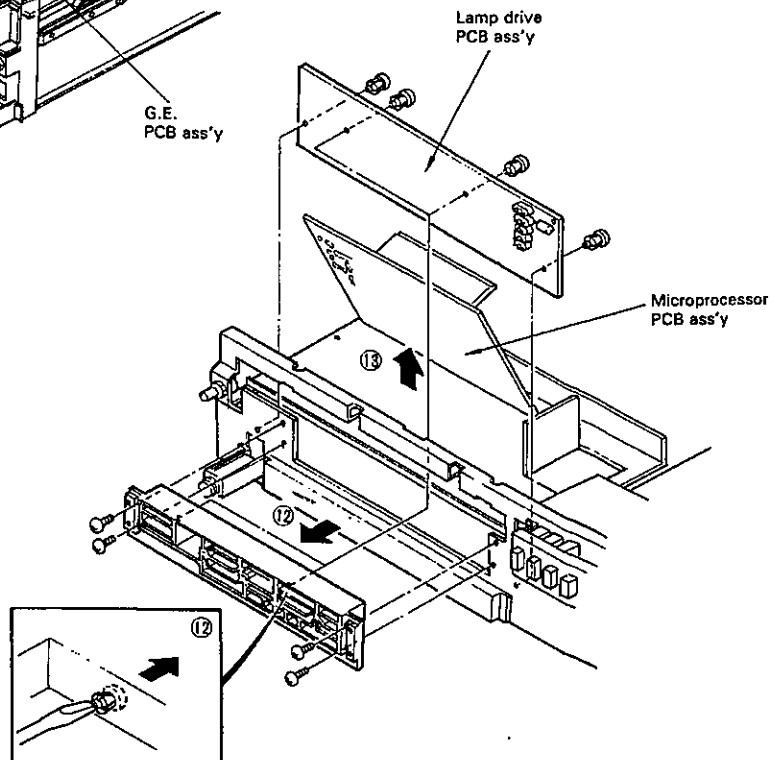
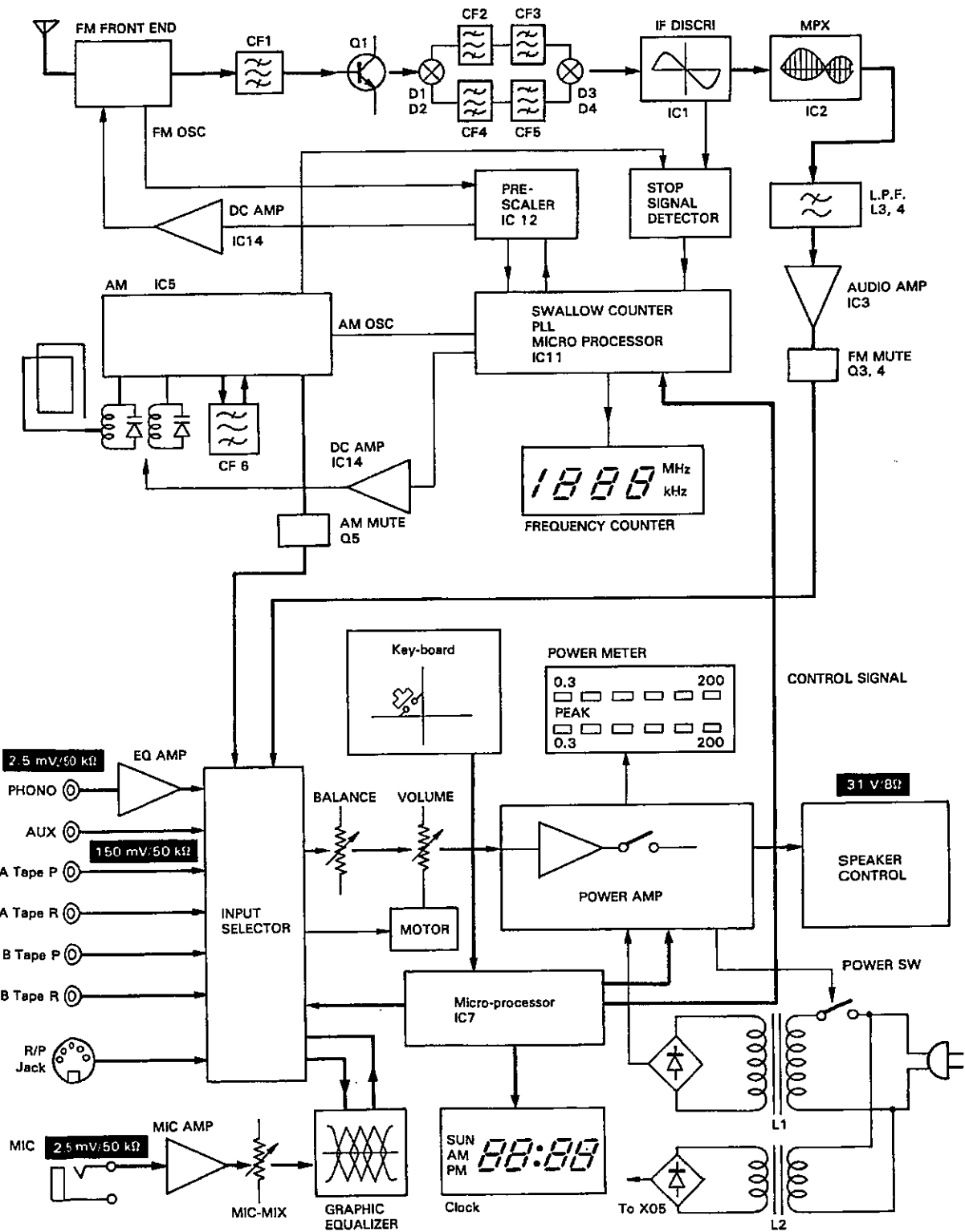

Fig. 7 (e)

BLOCK & LEVEL DIAGRAM



CIRCUIT DESCRIPTION

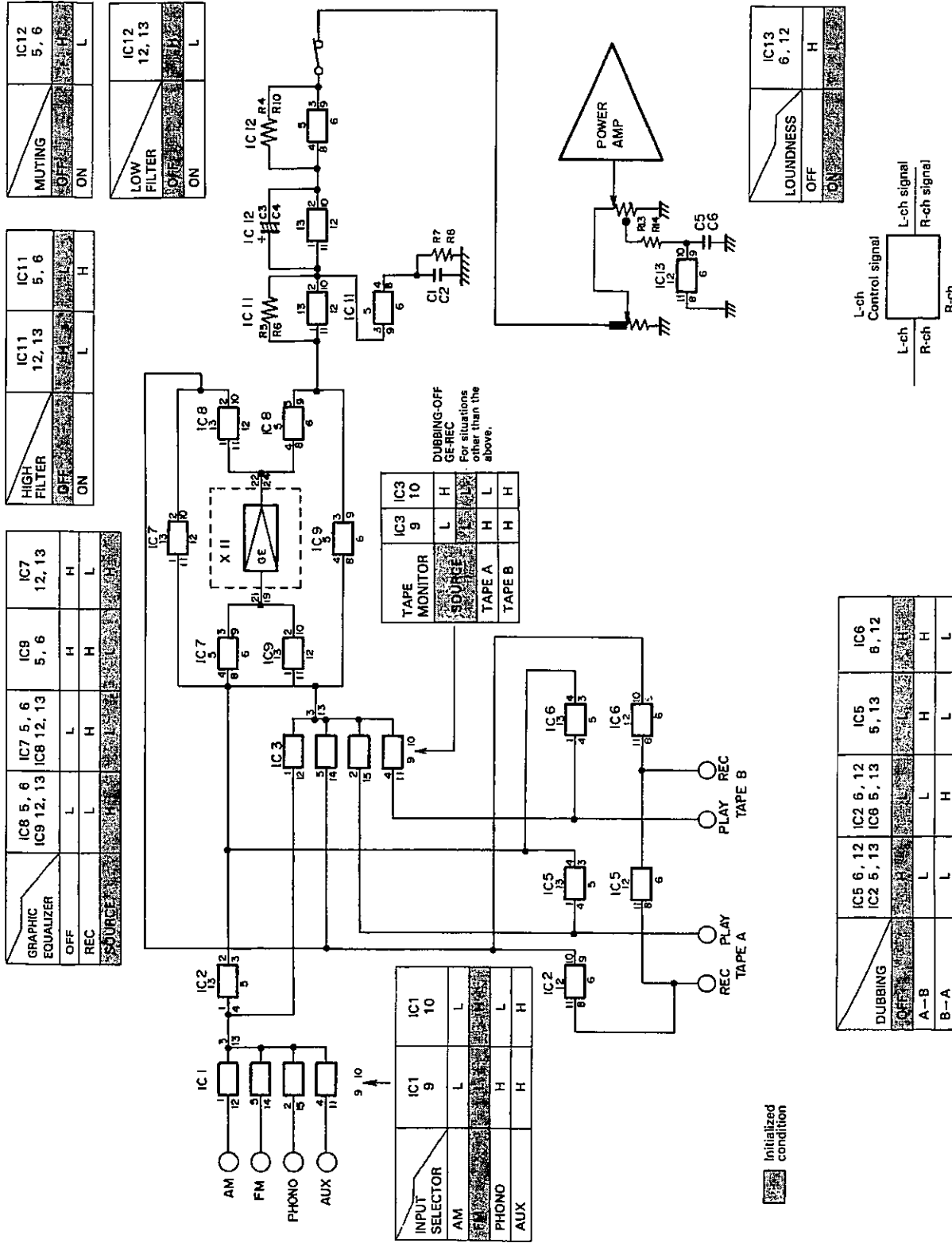

Fig. 9 Simplified Analog Switch Circuit

CIRCUIT DESCRIPTION

1. Analog Switch (X13-3160-10)

Fig. 9 shows a simplified analog switch circuit. The KR-1000 uses an analog switch IC (4066 and 4052) to select input sources. Each analog switch is ON when a high level signal is applied to the corresponding control terminal (4066: pin 5, 6, 12 or 13, 4052: pin 9 or/and 10); otherwise it is OFF.

The operation of IC 1 and 3 is shown in Fig. 10. IC 1 and IC 3 generate the decoded control signals and its signal controls 4 analog switches.

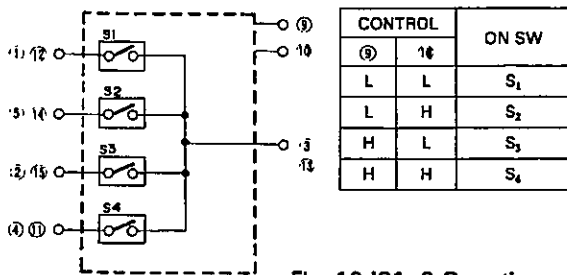

Fig. 10 IC1, 3 Operation

2. Microprocessor (X05)

The KR-1000 uses a microprocessor (μ PD553C-127) to control built-in clock, timer and key input operation.

The function of each pin of the microprocessor is shown in Fig. 13~15. Pin 7 is the initialization terminal to which a high level signal is momentarily applied to initialize all output terminal states when the AC plug is inserted in an AC outlet; the level of pin 7 is normally low. PC0~PC3, PDO~PD3, PH0~PH2 and PIO~PI2 output the analog switch control signals. The output signals of PGO~PG3 are decoded into 10 signals with IC6 (74LS42). These are used as the digit signals for the built-in clock, the preset station selecting signals and the clock signal for the latch IC (which latches the SPEAKER selecting signals and the LOW-FILTER ON/OFF signal). The function of IC6 is shown in Fig. 11. The output signals of PEO~PE3 are latched by IC9 (4042) as the SPEAKER selecting signals and the LOW-FILTER ON/OFF signal.

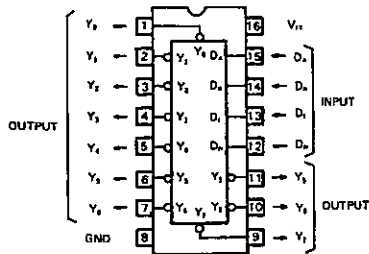

Fig. 11

D _p	D _c	D _b	D _a	Y ₀	Y ₁	Y ₂	Y ₃	Y ₄	Y ₅	Y ₆	Y ₇	Y ₈	Y ₉
L	L	L	L	L	H	H	H	H	H	H	H	H	H
L	L	L	H	H	L	H	H	H	H	H	H	H	H
L	L	H	L	H	H	L	H	H	H	H	H	H	H
L	L	H	H	H	H	H	L	H	H	H	H	H	H
L	H	L	L	H	H	H	H	L	H	H	H	H	H
L	H	L	H	H	H	H	H	H	L	H	H	H	H
L	H	H	L	H	H	H	H	H	H	L	H	H	H
L	H	H	H	H	H	H	H	H	H	H	L	H	H
H	L	L	L	H	H	H	H	H	H	H	H	L	H
H	L	L	H	H	H	H	H	H	H	H	H	H	L
H	L	H	L	H	H	H	H	H	H	H	H	H	H
H	L	H	H	H	H	H	H	H	H	H	H	H	H
H	H	L	L	H	H	H	H	H	H	H	H	H	H
H	H	L	H	H	H	H	H	H	H	H	H	H	H
H	H	H	L	H	H	H	H	H	H	H	H	H	H
H	H	H	H	H	H	H	H	H	H	H	H	H	H

CIRCUIT DESCRIPTION

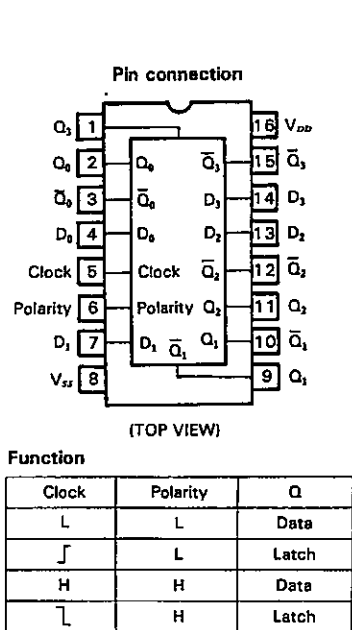

Fig. 12

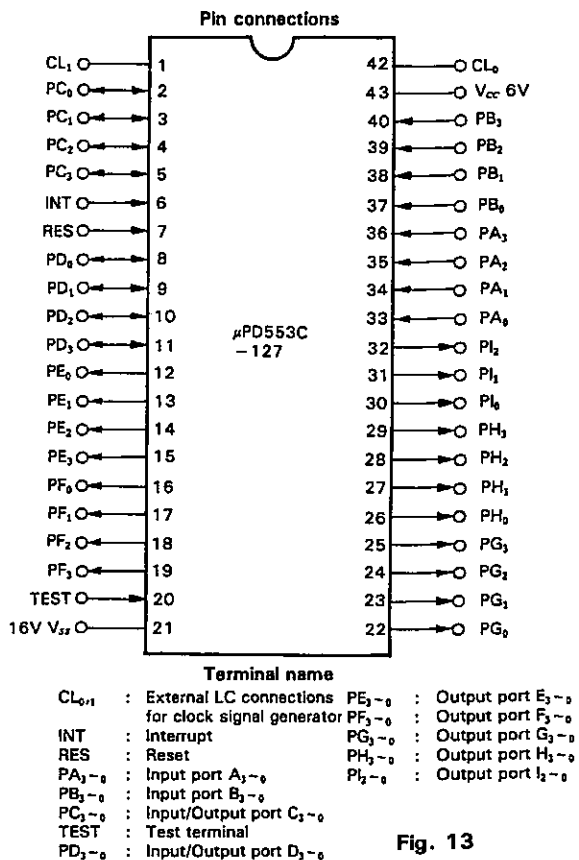

Fig. 13

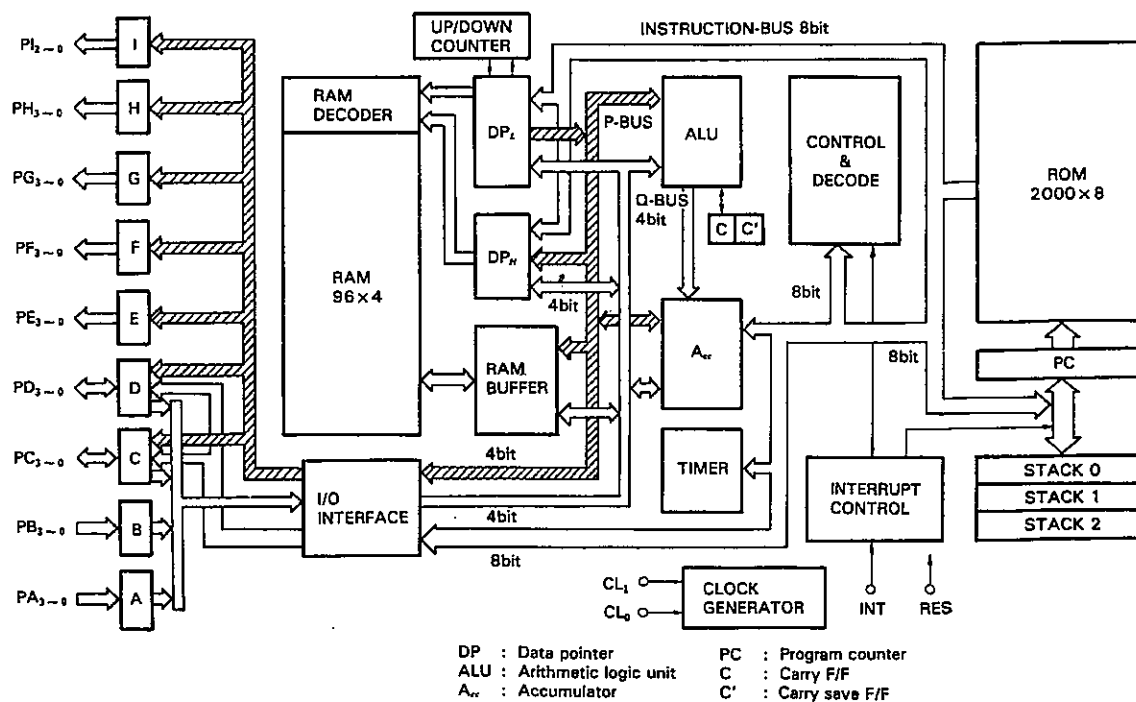
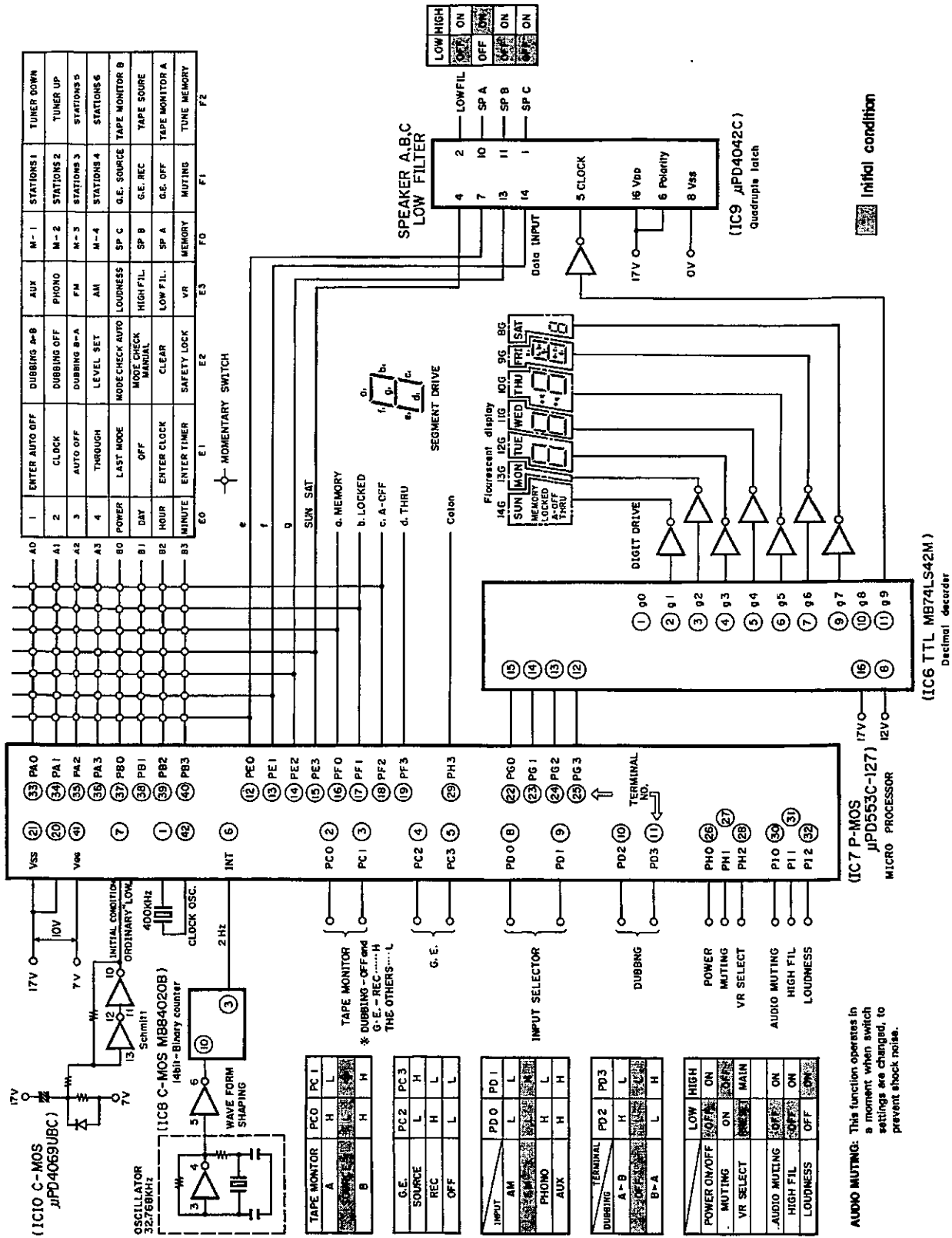

Fig. 14 Block Diagram

CIRCUIT DESCRIPTION



AUDIO MUTING: This function operates in a moment when switch settings are changed, to prevent shock noise.

CIRCUIT DESCRIPTION

3. Voltage regulator and dimmer circuit for lamps (X13-3160-10)

The KR-1000 has many built-in lamps. Variation of the lamp power supply voltage due to AC line voltage variations or variation in the output power will result in fluctuations in the amount of light output by the lamps. Therefore, the KR-1000 uses a voltage regulator to ensure stable power for the lamps.

See Fig. 16. Q33 is forward biased when the lamp ON/OFF signal level is "H" (+16 V) and the lamp is ON. The voltage at the emitter of Q33 is $V_z + 3 V_D$; i.e., it is the sum of the voltage across Zener diode D57 (V_z) and the forward voltages of diodes D77, D55 and D56 (V_D each), since these diodes are connected to the emitter in series. The emitter voltage of Q65 is then $V_z + 2 V_D$ since the base-emitter voltage of Q65 is regarded as V_D . Thus, the voltage applied to the lamp is kept constant ($V_z + 2 V_D$) even if the lamp power supply voltage varies.

Q33 is OFF when the lamp ON/OFF signal level is "L" (0 V) since Q33 is reverse biased. Then, Q65 is OFF and the voltage is not supplied to the lamp.

D55 and D56 are shorted when the dimmer switch is turned ON while the lamp ON/OFF signal level is "H". Then, the emitter voltage of Q33 becomes $V_z + V_D$ and the emitter voltage of Q65 becomes V_z . Thus, the lamp is dimmed. In practice, the lamp drive circuit drives many lamps.

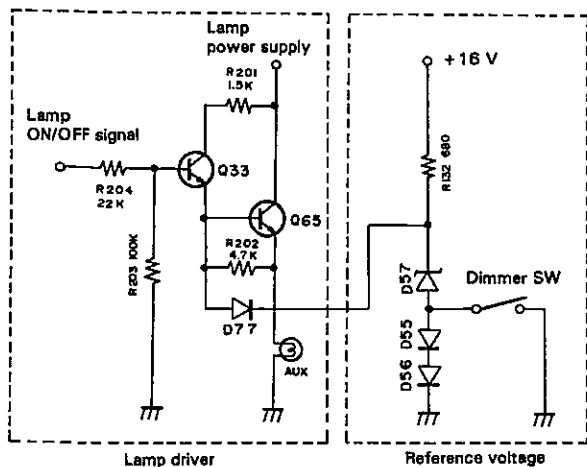

Fig. 16 Lamp Drive Circuit

4. Fluorescent Display Tube Dimmer Circuit

A conventional dimmer circuit for a fluorescent display tube, which is dynamically driven, controls the duty ratio of the digit control pulse signal to shorten the time during which the segments are lit. (See Page 20).

In the KR-1000, the duty ratio of the digit control pulse signal is not varied, but is switched at high speed as shown in Fig. 17 so that the time during which the segments are lit is shortened. This method is also effective for a fluorescent display tube which is driven statically. (See Fig. 17).

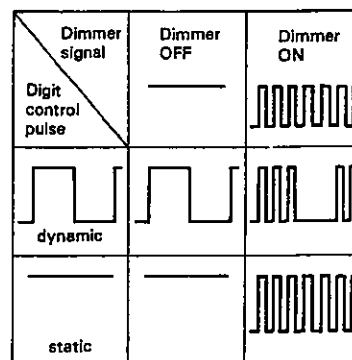

Fig. 17

Fig. 18 shows a dynamically driven fluorescent display tube dimmer circuit. A "H" level signal (+16 V) is applied to the dimmer signal input terminal when the dimmer function is OFF and Q46 is ON. Therefore, Q21 goes ON and its collector level becomes "H" when the digit out signal is "H", and Q21 is OFF and its collector level becomes "L" when the digit out signal is "L".

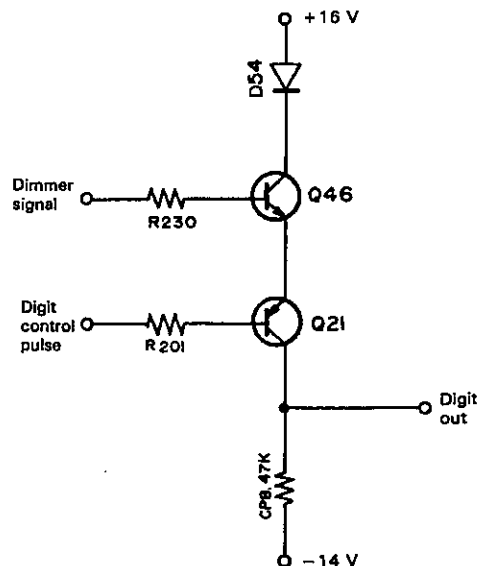

Fig. 18 Dynamic Drive Circuit

CIRCUIT DESCRIPTION

When the dimmer function is ON, a 16 kHz pulse signal is applied to the dimmer signal input terminal. Q21 and Q46 operate in the same manner as when the dimmer function is OFF while the 16 kHz pulse signal is "H". Q46 is OFF while the pulse signal is "L", so the collector level of Q21 is "L" regardless of the level of the digit out signal.

Fig. 19 shows a statically driven fluorescent display tube dimmer circuit. A "H" level (+16 V) signal is applied to the dimmer signal input terminal when the dimmer function is OFF and Q28 is OFF; so, the collector level of Q28 is "L" (-14 V). Since Q30 is OFF and its collector level is "H", both the base and emitter of Q29 are "H". A 16 kHz pulse signal is applied to the dimmer signal input terminal when dimmer function is ON. Q28, Q29 and Q30 operate in the same manner as when the dimmer function is OFF when the pulse signal level is "H". When the pulse signal level is "L", Q28 is ON and its collector level is "H", so the base level of Q30 is "H" and Q30 is ON. Therefore, the grid level of the fluorescent display tube is dropped to "L" through D23 since the collector level of Q30 is "L".

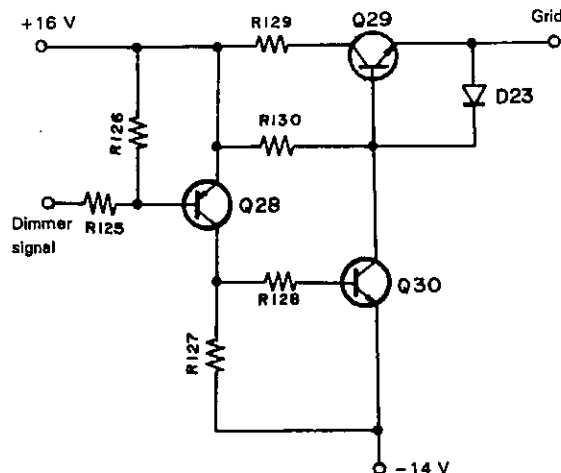

Fig. 19 Static Drive Circuit

5. Automatic Power Meter Range Switching Circuit (X11-1670-10)

The power meter range is switched manually in conventional amplifier systems, but with the KR-1000 it is automatically switched to the range in which the output power is easiest to read. The meter range is automatically changed from X0.1 to X1 when the output power increases to more than 20 W, and it is changed back to X0.1 when the output power is reduced to below 7 W.

In Fig. 20, Q21 and Q22 are emitter followers which prevent the automatic power meter range switching circuit being affecting the amplifier output circuits. The Q21 and Q22 output signals are rectified by the voltage doublers. When there is a difference between the output signal levels of the L and R

channels, the diode in the voltage doubler which is connected to the low level channel (i.e., D13 or D14) is reverse biased and only the voltage doubler which is connected to the high level channel operates to charge C55. The DC voltage across C55 increases the base voltage of Q23 of the Schmitt trigger according to the time constant determined by R108, R109 and C56.

The base voltage of Q23 does not rise to turn it ON when the output power is relatively low. Therefore, the Schmitt trigger output level (at the collector of Q24) is not inverted and is kept at the "L" level. Thus, the collector level of Q25 is "H" and FET switches Q26 and Q27 are ON. The signals from the emitters of Q21 and Q22 pass through Q26 and Q27, then are applied to the fluorescent display tube drive ICs (IC5 and IC6) via the voltage doublers after being divided by the ON resistance (several tens of ohms) and R119 and R120, respectively. The collector level of Q25 is applied to pin 31 of the fluorescent display tube to light the X0.1 indicator on the display.

When the output power is relatively high, Q23, is ON and the Schmitt trigger output level is "H". Thus, the collector level of Q25 is "L" and Q26 and Q27 are OFF. The output signals of Q21 and Q22 are then divided by R117 and R119, and R118 and R120, respectively. Then they are applied to IC5 and IC6 via the voltage doublers. The collector level "L" of Q25 is applied to pin 31 of the fluorescent display tube so the X0.1 indicator goes OFF.

The reason the range switching level is different when the power increases from that when the power decreases is due to the hysteresis characteristics of the Schmitt trigger.

CIRCUIT DESCRIPTION

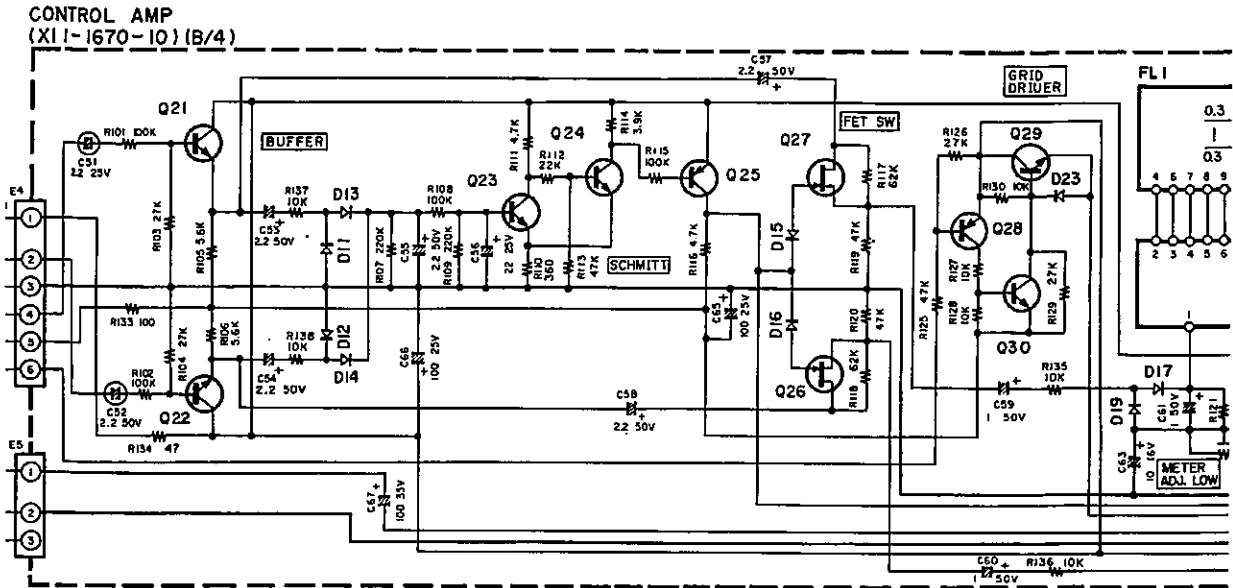

Fig. 20 Automatic Power Meter Range Switching Circuit

6. Motor Drive Circuit

The KR-1000 uses a motor to control increases and decreases in sound volume. The volume control variable resistor (hereafter called MAIN-VR) is automatically set to the position which is determined by the preset variable resistor (PRESET-VR) when the power is turned ON. Thus, a certain volume level is always obtained when the power is turned ON. The volume level can then be manually changed by pressing the MAIN-VR UP or DOWN switch.

Fig. 21 shows the MAIN-VR control motor drive circuit. AMP-1 is an inverting amplifier with high gain. It becomes saturated and its output level becomes equal to the negative power supply voltage (-8 V) as soon as the input level exceeds 0 V . Its output level becomes equal to the positive power supply voltage ($+8\text{ V}$) when the input level is less than 0 V . Fig. 22 (a) shows the input voltage vs. output voltage characteristic of AMP-1.

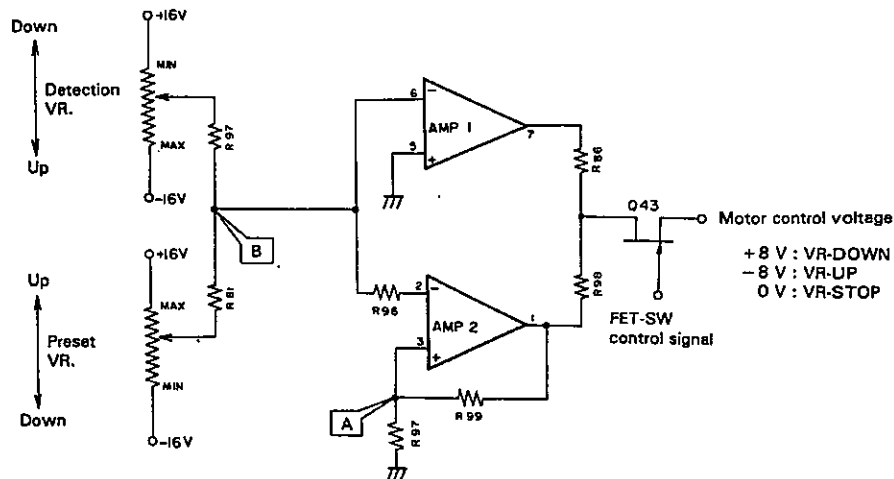

Fig. 21 Motor Control Circuit

CIRCUIT DESCRIPTION

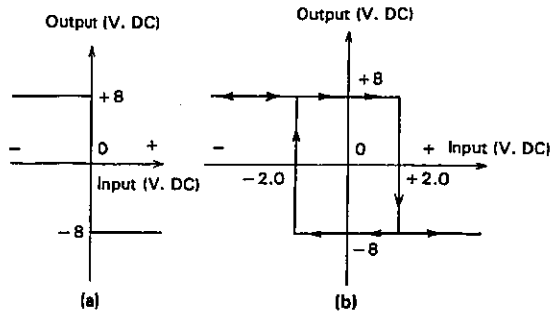

Fig. 22 Input vs. Output

AMP-2 operates as a Schmitt circuit. If the initial AMP-2 output level is -8 V , the voltage at point A (V_A) is given by

$$V_A = \frac{R97 \cdot V_o}{R97 + R99}$$

where V_o : output voltage

V_A is -2.0 V DC when $V_o = -8\text{ V}$, $R97 = 51\text{ k}\Omega$ and $R99 = 150\text{ k}\Omega$. At this time, the output level is inverted when the input voltage is lower than -2.0 V DC and it is not inverted when the input level is -2.0 V DC or higher. V_A is 2.0 V DC when the output level is $+8\text{ V}$. At this time, the output level is inverted when the input level is higher than 2.0 V DC and it is not inverted when the input level is 2.0 V DC or lower. Fig. 22 (b) shows the input voltage vs. output voltage characteristic of AMP-2. The input voltage vs. output voltage characteristic of the motor control circuit is shown in Fig. 23.

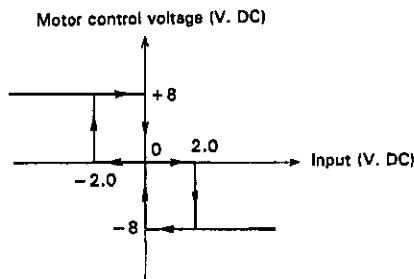

Fig. 23 Input vs. Motor Control Voltage

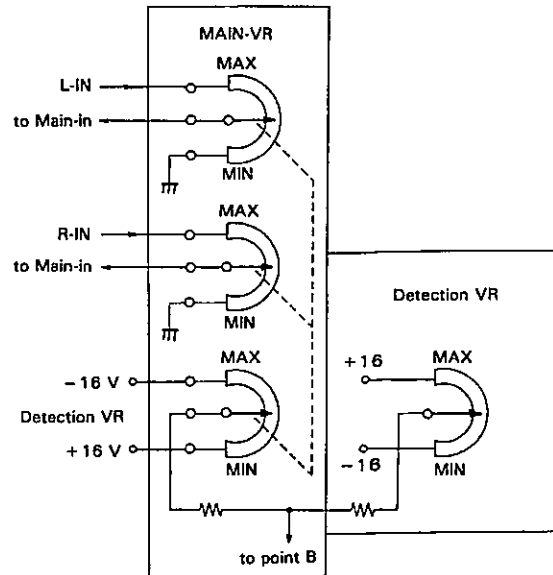

Fig. 24

The MAIN-VR incorporates variable resistors for adjusting the L and R channel volume levels and a variable resistor to detect the MAIN-VR setting position. The latter is called the detection VR. (See Fig. 24) The detection VR slider terminal level is -16 V when the MAIN-VR is set to MAX, and it is $+16\text{ V}$ when the MAIN-VR is set to MIN. The preset VR slider terminal level is $+16\text{ V}$ when the preset VR is set to MAX and it is -16 V when it is set to MIN. The voltage at point B is 0 V when the detection VR is set to the same position as the preset VR. It is positive when the detection VR is set to a higher sound level than the preset VR, and vice versa. The motor control voltage becomes -8 V when the voltage at point B is higher than 2.0 V . Therefore, the MAIN-VR is turned by the motor to increase the volume level until the voltage at point B becomes 0 V . The motor control voltage becomes $+8\text{ V}$ when the voltage at point B is lower than -2.0 V , so the MAIN-VR is turned to lower the volume level until the voltage at point B becomes 0 V .

A "H" level signal is applied to the gate of Q43 when the power is turned ON. Therefore, Q43 goes ON and outputs the motor control signal according to the voltage at point B. Pressing either the MAIN-VR UP, or DOWN switch sets the gate level of Q43 to "L". Thus, Q43 goes OFF and the volume control can be adjusted manually.

CIRCUIT DESCRIPTION

7. Variable Power Supply

The KR-1000 uses analog switches to select input sources. The IC (μ PD4066C) which incorporates analog switches has a maximum power supply voltage rating of just ± 9 V. If the circuit shown in Fig. 25 were used, the input signal would be clipped in the analog switch circuit when the input signal exceeds the power supply voltage. This would prevent sufficient dynamic range from being obtained. (See Fig. 26).

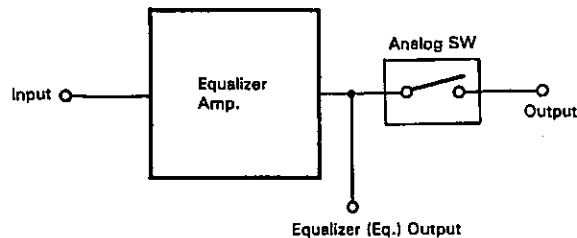

Fig. 25

To avert this, the positive and negative power supply voltages to the analog switches are shifted simultaneously according to the input signal level, as shown in Fig. 27, so that the input source signal is not clipped in the analog switch.

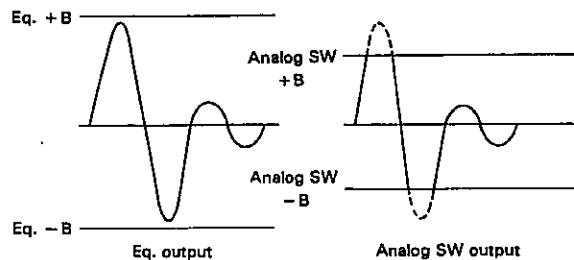

Fig. 26

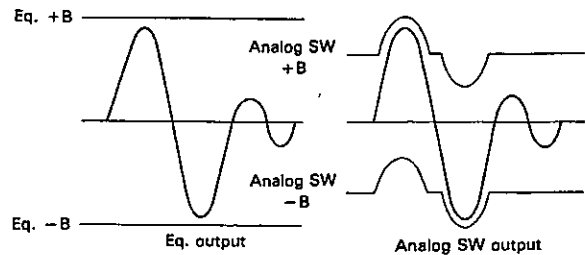

Fig. 27

The principle of the variable power supply is explained with Fig. 28 (a). The circuit is an ordinary feedback type voltage regulator if the part indicated by the dotted line is not included. If the base voltage of Q20 is V_B and the emitter voltage of Q19 is V_E , then when the DC source voltage V is equal to V_B , no current flows through R45 and V_E does not vary. When $V > V_B$, the base current of Q20 increases because of the current through R46. Thus, the collector current of Q20 increases and the collector level drops so that the base voltage of Q19 and V_E drop. When $V < V_B$, current flows into the DC source through R46 and the base current of Q20 decreases, so the collector current decreases and the collector level rises. Thus, the base voltage of Q19 rises and V_E rises.

When the section enclosed in the dotted line is replaced with the AC power source shown in Fig. 28 (b), V_E varies 180 degrees out of phase with E .

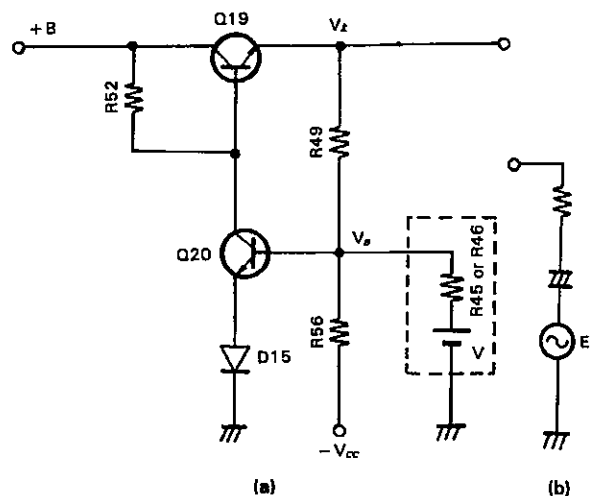

Fig. 28

CIRCUIT DESCRIPTION

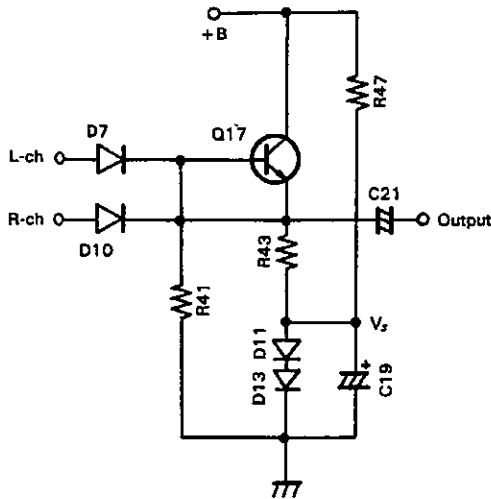

Fig. 29

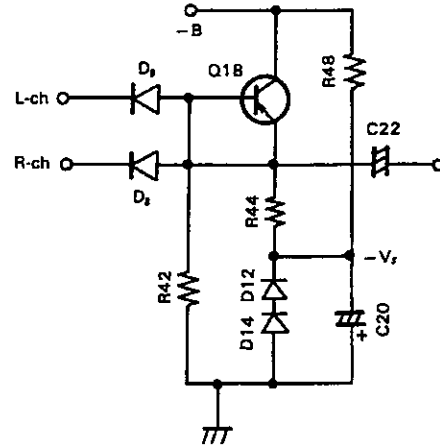

Fig. 30

It is not necessary to shift the power supply voltages when the input signal level is low and it is not clipped in the analog switch. The input signal is sliced by the circuit shown in Fig. 29, 30 so that output is obtained only when the input signal level exceeds a certain level. In Fig. 29, the diode which is connected to the channel whose signal level is higher than that of the other channel is forward biased and turned ON and the other diode is reverse biased and turned OFF. Thus, the higher level signal is applied to the bases of Q17. When no signal is applied, Q17 is OFF and its emitter level is equal to the sum of the ON voltages of D11 and D13. Q17 is turned ON when the voltage applied to its base exceeds V_{BE} (base-emitter voltage of Q17) plus V_z (the emitter voltage of Q17). Thus, Q17 outputs a signal at this time (See Fig. 31). The circuit shown in Fig. 29 slices the positive parts of the input signal and that shown in Fig. 30 slices the negative parts of the input signal. These signals are used to drive the base of Q20 (shown in Fig. 28) so that V_z is shifted according to the input signal level. The negative power supply voltage for the analog switch is generated by Zener diode D17 according to the level of V_z .

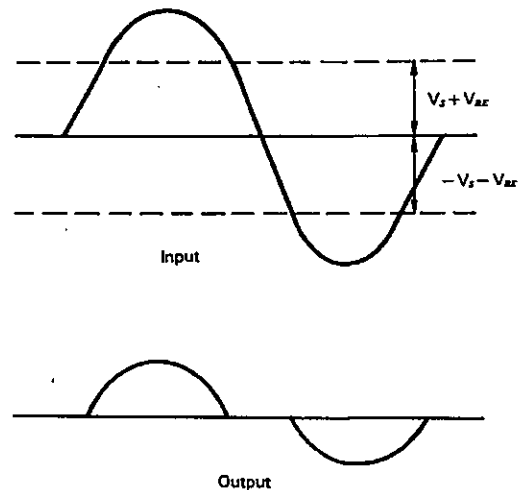

Fig. 31

8. Power Supply System

Fig. 32 shows the power supply system of the KR-1000. Transformer 2 is always supplied with power when the AC plug is inserted into an AC outlet; it supplies power to the microprocessor and synthesizer units. Transistors Q31, Q34, Q35 and Q36 from the +16 V, +11 V, +6 V and -14 V voltage regulators, respectively.

CIRCUIT DESCRIPTION

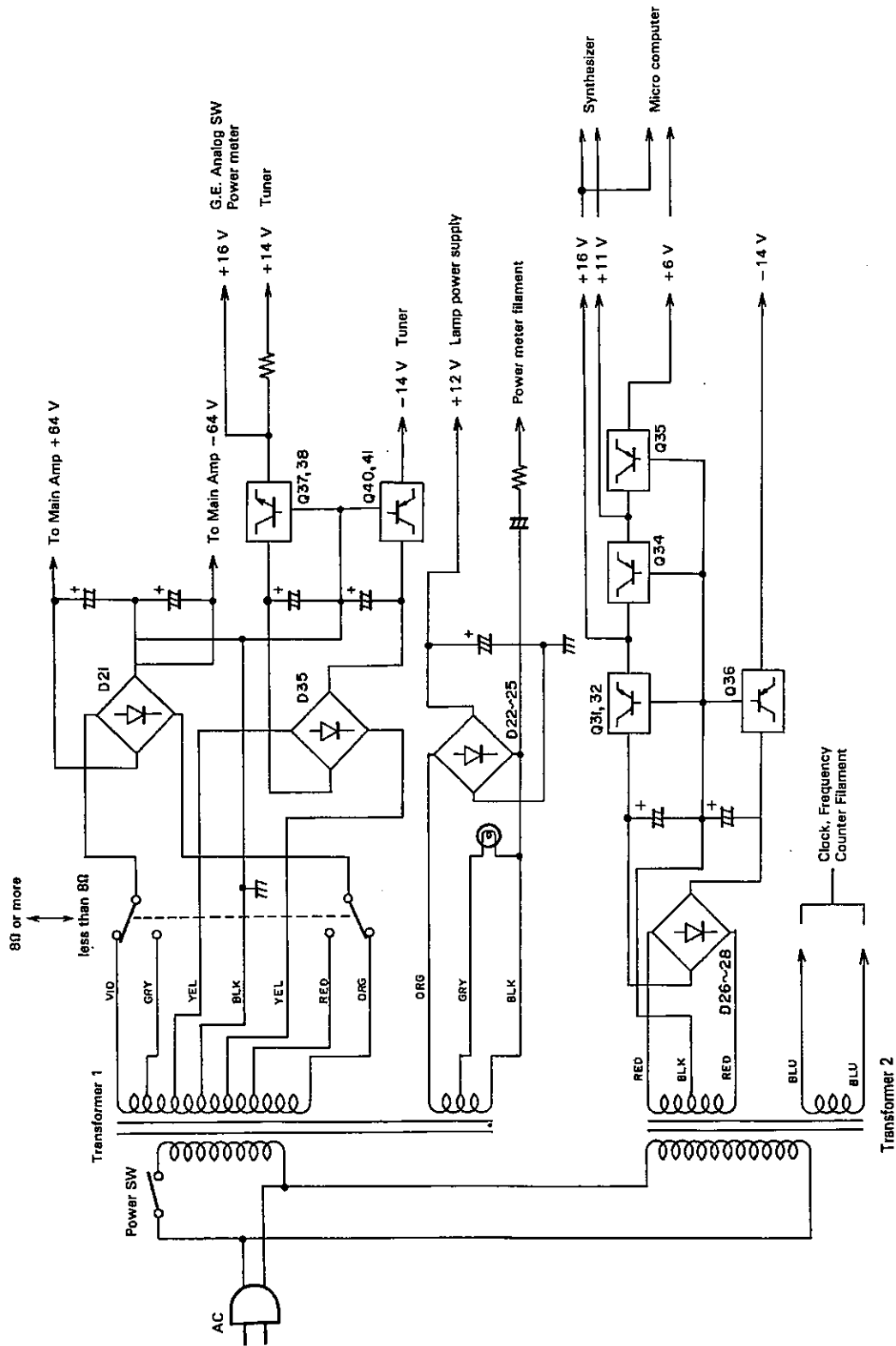

Fig. 32

CIRCUIT DESCRIPTION

7-SEGMENT MULTI-DIGIT INDICATOR DRIVING SYSTEM

There are two types of systems used for driving 7-segment multi-digit indicators and LED's: the static drive system and the dynamic drive system.

In the static drive system, the signal lines are connected to each segment of all the digits and the content of the display does not change with time.

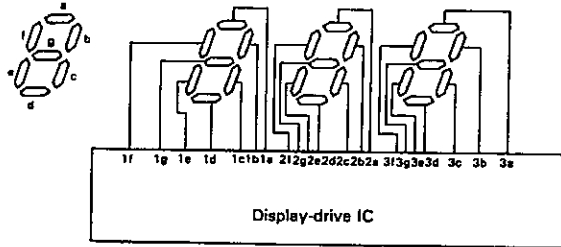

Assuming that each segment lights when its drive IC terminal is in the "H" (on) position, "123" is displayed as:

1a="L",	1b="H",	1c="H",	1d="L",
	1e="L",	1f="L",	1g="L",
2a="H",	2b="H",	2c="L",	2d="H",
	2e="H",	2f="L",	2g="H",
3a="H",	3b="H",	3c="H",	3d="H",
	3e="L",	3f="L",	3g="H",

The output of the drive IC does not change as long as "123" is being displayed.



The drive circuit itself is simple in this system, but there must be a 1 : 1 correspondence between drive IC terminals and segments. This means that an increase in the number of digits displayed requires a increase in the number of IC terminals.

This relationship is expressed by $n = 7d + c$
 (where, n: the number of the pins of the drive IC
 d: the number of digits
 c: the number of other IC terminals)

In a 3-digit display, the number of the pins of the drive IC is slightly more than 21, while in a 6-digit display it is 42 or more; this is more than the number of the pins found on an ordinary 40-pin LSI.

In the dynamic drive system, the segments in the same position in each digit are connected in parallel to the same signal line. Separate signal lines which indicate which digit is to be displayed are connected to each digit; these cause the segment signals to be applied to different digits on an alternating basis.

For example,

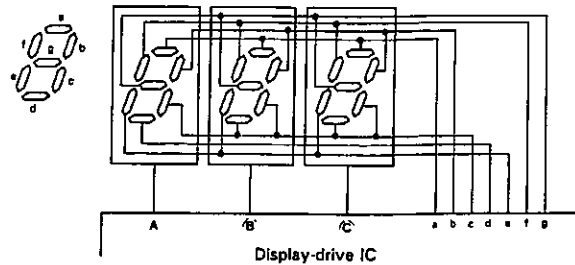

If all digit segments light when both the digit terminals (A ~ C) and segment terminals (a-g) of the drive IC are all set "H" (on), "123" would be displayed as follows:

The above outputs will cycle in sequence.

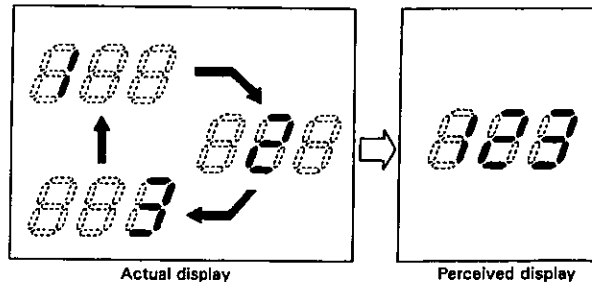

If the frequency with which the outputs are cycled is low, the display digits will appear to flicker; for high frequencies, all digits will appear to be steadily lit. Although the drive circuit is highly sophisticated in this system, use of microcomputers, etc., in the drive IC virtually eliminates any problems.

The relationship between the number of display digits and drive IC terminals is given by $n = 7d + c$
 (where, n: the number of the pins of the drive IC
 d: the number of digits
 c: the number of other IC terminals)

In a 3-digit display, the number of the pins of the drive IC may be only slightly more than 10, and in a 6-digit display it may also be only 13, which means a large decrease in the number of the pins compared with the static drive. The two systems explained above are used in various electronic applications depending upon their adaptability.

The static drive is used in applications such as audio timers, etc., which required relatively simple circuits with fewer digits, while the dynamic drive is employed in equipment incorporating microcomputers, such as FM synthesizer tuners.

ADJUSTMENT

NO.	ITEM	SYSTEM CONNECTIONS	TEST EQUIPMENT SETTING	TUNER (RECEIVER) SETTING	ALIGNMENT POINTS	ALIGN FOR	FIG. NO.
FM SECTION							
1	DISCRIMINATOR (1)	(A)/Connect a DC voltmeter between terminals TPA and TPB.	100.1MHz 1kHz \pm 75kHz dev 60dB (ANT input)	FM MONO 100.1MHz WIDE	L1	0 \pm 400mV	(a)
2	DISCRIMINATOR (2)	(A) / (B)	100.1MHz 1kHz \pm 75kHz dev 60dB (ANT input)	FM MONO 100.1MHz WIDE	L2	Minimum distortion	
3	VCO	(A)/Connect a frequency counter to the junction of R31 and VR3 via an AC voltmeter.	100.1MHz 0 dev 100dB (ANT input)	FM STEREO 100.1MHz	VR3	Frequency: 76kHz \pm 200Hz	(b)
VCO: Voltage Controlled Oscillator							
4	SEPARATION (WIDE)	(C) / (B)	100.1MHz 1kHz \pm 68.25kHz dev Selector: L or R Pilot: \pm 6.75kHz dev 60dB (ANT input)	FM STEREO 100.1MHz WIDE	VR5	Minimum crosstalk. A compromise adjustment may be required if left-to-right and right-to-left separations are unequal.	
5	PLOT CANCELLER	(C) / (B)	100.1MHz Pilot signal 60dB	FM STEREO 100.1MHz	VR4	Minimum output	
6	DISTORTION (STEREO)	(C) / (B)	100.1MHz 1kHz \pm 68.25kHz dev Selector: L or R Pilot: \pm 6.75kHz dev 60dB (ANT input)	FM STEREO 100.1MHz	T2 (Front end)	Minimum distortion	
AM SECTION Keep the AM loop antenna installed.							
(1)	BAND EDGE (1)	(D)/Connect a DC voltmeter to TP6	1620kHz (1611) 400Hz, 30% mod	AM 1620kHz (1611)	TC1	DC voltage for ground: 8.5V	(c)
(2)	BAND EDGE (2)	(D)/Connect a DC voltmeter to TP6	530kHz (522) 400Hz, 30% mod	AM 530kHz (522)	L6	DC voltage for ground: 1.0V	(e)
(3)	RF ALIGNMENT (AM)	(D) / (B)	630kHz 400Hz, 30% mod	AM 630kHz	L5	Maximum amplitude and symmetry of the oscilloscope display.	
(4)	RF ALIGNMENT (AM)	(D) / (B)	1440kHz 400Hz, 30% mod	AM 1440kHz	TC2	Maximum amplitude and symmetry of the oscilloscope display.	
Repeat alignments (3) and (4) several times.							
(5)	IF TRANSFORMER	(D) / (B)	990kHz 400Hz, 30% mod	AM 990kHz	L7	Maximum amplitude and symmetry of the oscilloscope display.	
(6)	AM STOP LEVEL	(D)	990kHz 400Hz, 30% mod 30dB (antenna input)	AM 990kHz SENSI-2	VR6	Adjust so that the tuned lamp just lights.	
(7)	FLUORESCENT DISPLAY TUBE BRIGHTNESS ADJUSTMENT	—	—	—	VR7	Match the brightness of the power meter and the frequency counter.	
AUDIO SECTION							
i	OFFSET (CENTER)	Connect a DC voltmeter between J10 (J11) and the ground	—	PHONO VOLUME 0	VR1 (L ch) VR2 (R ch) X00	0V	(d)
ii	IDLE CURRENT (BIAS)	Connect a DC voltmeter between terminals TP12 and TP13 (TP14 and TP15)	—	AUX VOLUME 0	VR1 (L ch) VR2 (R ch) X07	40–60mV	(e)
iii	POWER METER	(E) / (F)	1kHz 1V	METER range: \times 0.1 Adjust VOLUME so that AC voltmeter indicates 0.49V	MET.ADJ.LOW VR11 (VR12)	0.03W	
iv	POWER METER	(E) / (F)	1kHz 1V	METER range: \times 0.1 Adjust VOLUME so that AC voltmeter indicates 8.9V	MET.ADJ.HIGH VR13 (VR14)	10W	
Repeat alignments "iii, iv" several times.							

REGLAGES

N°	ITEM	RACCORDEMENTS DU SYSTEME	REGLAGE DE L'APPAREILLAGE	REGLAGE DU TUNER (AMPLI-TUNER)	POINTS DE L'ALIGNEMENT	ALIGNER POUR	FIG. N°
SECTION MF							
1	DISCRIMINATEUR (1)	(A)/Connecter un voltmètre CC entre terminales TPA et TPB	100,1MHz 1kHz ± 75kHz dév 60dB (Entrée ANT)	FM 100,1MHz WIDE	L1	0 ± 400mV	(a)
2	DISCRIMINATEUR (2)	(A) / (B)	100,1MHz 1kHz ± 75kHz dév 60dB (Entrée ANT)	FM MONO 100,1MHz WIDE	L2	Distorsion minimale	
3	OSCILLATEUR CONTROLE PAR LA TENSION	(A)/Connecter un compteur de fréquence à la jonction de R31 et VR3 par un voltmètre CA	100,1MHz 0 dév 100dB (Entrée ANT)	FM STEREO 100,0MHz	VR3	Fréquence: 76kHz ± 200Hz	(b)
4	SEPARATION (WIDE)	(C) / (B)	100,1MHz 1kHz ± 68,25kHz dév Selection: L ou R Signal pilote: ± 6,75kHz dév 60dB (Entrée ANT)	FM STEREO 100,1MHz WIDE	VR5	Diaphonie minimale. Un compromis de réglage peut être nécessaire si les séparations de gauche à droite et de droite à gauche sont inégales.	
5	CIRCUIT SUPPRESSION DE SIGNAL PILOTE	(C) / (B)	100,1MHz Signal pilote 60dB (Entrée ANT)	FM STEREO 100,1MHz	VR4	Sortie minimale	
6	DISTORSION (STEREO)	(C) / (B)	100,1MHz 1kHz ± 68,25kHz dév SELECTION L ou R Signal pilote ± 6,75kHz dév 60dB (Entrée ANT)	FM STEREO 100,1MHz	T2 (Tête H.T.)	Distorsion minimale	
SECTION MA Laisser l'antenne boucle MA installée.							
(1)	ALIGNEMENT H.T. (MA)	(D)/Connecter un voltmètre CC à TP6	1620kHz (1611) 400Hz, 30% mod	AM 1620kHz (1611)	TC1	Tension continue pour terre: 8,5V	(c)
(2)	ALIGNEMENT H.T. (MA)	(D)/Connecter un voltmètre CC à TP6	530kHz (522) 400Hz, 30% mod	AM 530kHz (522)	L6	Tension continue pour terre: 1,0V	(c)
(3)	ALIGNEMENT H.T. (MA)	(D) / (B)	630kHz 400Hz, 30% mod	AM 630kHz	L5	Amplitude et symétrie maximale de l'affichage de l'oscilloscope.	
(4)	ALIGNEMENT H.T. (MA)	(D) / (B)	1440kHz 400Hz, 30% mod	AM 1440kHz	TC2	Amplitude et symétrie maximale de l'affichage de l'oscilloscope.	
Répéter les points (3) et (4) plusieurs fois.							
(5)	TRANSFORMATEUR F.I.	(D) / (B)	990kHz 400Hz, 30% mod	AM 990kHz	L7	Amplitude et symétrie maximale de l'affichage de l'oscilloscope.	
(6)	NIVEAU D'ARRÊT EN AM	(D)	990kHz 400Hz 30% mod 30dB (entrée d'antenne)	AM 990kHz SENSI-2	VR6	Régler de façon que le voyant accordé s'allume.	
(7)	REGLAGE DE BRILLANCE DE L'AFFICHAGE FLUORESCENT				VR7	Faites coïncider la brillance du compteur de puissance et du fréquence-mètre.	
SECTION AUDIO							
i	DECALAGE (CENTER)	Connecter un voltmètre CC entre J10 (J11) et la terre	—	PHONO VOLUME: 0	VR1 (gauche) (VR2 (droit)) X00	0V	(d)
ii	COURANT DE POLARISATION (BIAS)	Connecter un voltmètre CC entre terminales TP12 et TP13 (TP14 et TP15)	—	AUX VOLUME: 0	VR1 (gauche) (VR2 (droit)) X07	40 - 60mV	(e)
iii	POWER METRE	(E) / (F)	1kHz 1V	Régler le VOLUME en sorte que le VU-mètre indique 3W lorsque le voltmètre indique 0,49V	MET ADJ LOW VR11 (VR12)	0,03W	
iv	POWER METRE	(E) / (F)	1kHz 1V	Régler le VOLUME en sorte que le VU-mètre indique 3W lorsque le voltmètre indique 8,9V	MET ADJ HIGH VR13 (VR14)	10W	
Répéter les points iii et iv plusieurs fois.							

ABGLEICH

NR.	GEGENSTAND	SYSTEM-ANSCHLÜSSE	PRÜFENRICHTUNG-EINSTELLUNG	TUNER (RECEIVER)-EINSTELLUNG	ABGLEICH-PUNKTE	ABGLEICHEN FÜR	ABB. NR.
UKW-ABTEILUNG							
1	DISKRIMINATOR (1)	(A)/Einen Gleichspannungsmesser zwischen Klemmen TPA und TPB.	100.1MHz 1kHz ± 75kHz Hub 60dB (ANT-Eingang)	FM MONO 100.1MHz WIDE	L1	0 ± 400mV	(a)
2	DISKRIMINATOR (2)	(A) / (B)	100.1MHz 1kHz ± 75kHz Hub 60dB (ANT-Eingang)	FM MONO 100.1MHz WIDE	L2	Minimale Klirrfaktor	
3	SPANNUNGS-GEREGELTER OSZILLATOR	(A)/Einen Frequenzmesser zur Verbindung von R31 und VR3 über einem Wechselspannungsmesser anschließen.	100.1MHz 0 Hub 100dB (ANT-Eingang)	FM MONO 100.1MHz	VR3	Frequenz: 76kHz ± 200Hz	(b)
4	STEREO KANAL TRENNUNG (WIDE)	(C) / (B)	100.1MHz 1kHz ± 68,25kHz Hub Wähler: L oder R Pilotton: ± 6,75kHz Hub 60dB (ANT-Eingang)	FM STEREO 100.1MHz WIDE	VR5	Minimales Übersprechen. Eine Ausgleichregelung kann notwendig sein, falls links-zu-rechts und rechts-zu-links Trennungen ungleich sind.	
5	PILOT-LÖSCHER	(C) / (B)	100.1MHz Pilotsignal 60dB	FM STEREO 100.1MHz	VR4	Minimale Ausgang	
6	KLIRRFaktor (STEREO)	(C) / (B)	100.1MHz 1kHz ± 68,25kHz Hub Wähler: L oder R Pilotton: ± 6,75kHz Hub 60dB (ANT-Eingang)	FM STEREO 100.1MHz	T2 (Frontende)	Minimale Klirrfaktor	
MW-ABTEILUNG Die MW-Rahmenanagenne angebracht lassen.							
(1)	HF-ABGLEICH (MW)	(D)/Einen Gleichspannungsmesser zu TP6	1620kHz (1611) 400Hz, 30% mod	AM 1620kHz (1611)	TC1	Gleichspannung für Erde: 8.5V	(c)
(2)	HF-ABGLEICH (MW)	(D)/Einen Gleichspannungsmesser zu TP6	530kHz (522) 400Hz 30% mod	AM 530kHz (522)	L6	Gleichspannung für Erde: 1.0V	(c)
(3)	HF-ABGLEICH (MW)	(D) / (B)	530kHz 400Hz 30% mod	AM 630kHz	L5	Maximale Amplitude und Symmetrie des Oszilloskopbildes.	
(4)	HF-ABGLEICH (MW)	(D) / (B)	1440kHz 400Hz, 30% mod	AM 1440kHz	TC2	Maximale Amplitude und Symmetrie des Oszilloskopbildes.	
Abstimmungen (3) und (4) mehrere Male wiederholen.							
(5)	ZF-ÜBERTRAGER	(D) / (B)	990kHz 400Hz, 30% mod	AM 990kHz	L7	Maximale Amplitude und Symmetrie des Oszilloskopbildes.	
(6)	AM-SPERRSCHWELLE	(D)	990kHz, 400Hz 30% mod 30dB (Antenneneingang)	AM 990kHz SENSI-2	VR6	So einstellen, daß die abgestimmte Anzeigelampe gerade aufleuchtet.	
(7)	HELLIGKEITSEINSTELLUNG DER FLUORESCENZANZEIGE				VR7	Die Helligkeit des Leistungsmeters und des Frequenzzählers aufeinander abstimmen.	
AUDIO-ABTEILUNG							
i	VERSCHIEBUNG (CENTER)	Einen Gleichspannungsmesser zwischen Klemme J10 (J11) und der Erde.	—	PHONO VOLUME: 0	VR1 (linken Kanal) VR2 (rechten Kanal)	0V	(d)
ii	LEERLAUFSTROM (BIAS)	Einen Gleichspannungsmesser zwischen Klemmen TP12 und TP13 (TP14 und TP15)	—	AUX VOLUME: 0	VR1 (linken Kanal) VR2 (rechten Kanal)	40-60mV	(e)
iii	LEISTUNGSMESSER	(E) / (F)	1kHz 1V	Den VOLUMEN so regulieren, daß die Gleichspannungsmesser Ablesung 0.49V ist.	MET ADJ LOW VR11 (VR12)	0.03W	
iv	LEISTUNGSMESSER	(E) / (F)	1kHz 1V	Den VOLUMEN so regulieren, daß die Gleichspannungsmesser Ablesung 8.9V ist.	MET ADJ LOW VR13 (VR14)	10W	
Abstimmungen "iii und iv" mehrere Male wiederholen.							

KR-1000/B KR-1000/B

ADJUSTMENT/REGLAGES/ABGLEICH

TEST INSTRUMENT	APPAREILLAGE	PRÜFINSTRUMENTE
Oscilloscope	Générateur MA	Oszilloskop
AM signal generator	Générateur MF	MW-Signalgenerator
FM signal generator	Voltmètre CA	UKW-Signalgenerator
Audio generator	Générateur multiplex stéréo	NF-Signalgenerator
AC voltmeter	Voltmètre CC	Wechselspannungsmesser
FM multiplex generator	Distorsionmètre	UKW-Multiplexgenerator
Frequency counter	Antenne fictive	Frequenzzähler
DC voltmeter		Gleichspannungsmesser
Distortion meter		Klirfaktormesser
Dummy antenna		Antennennachbildung

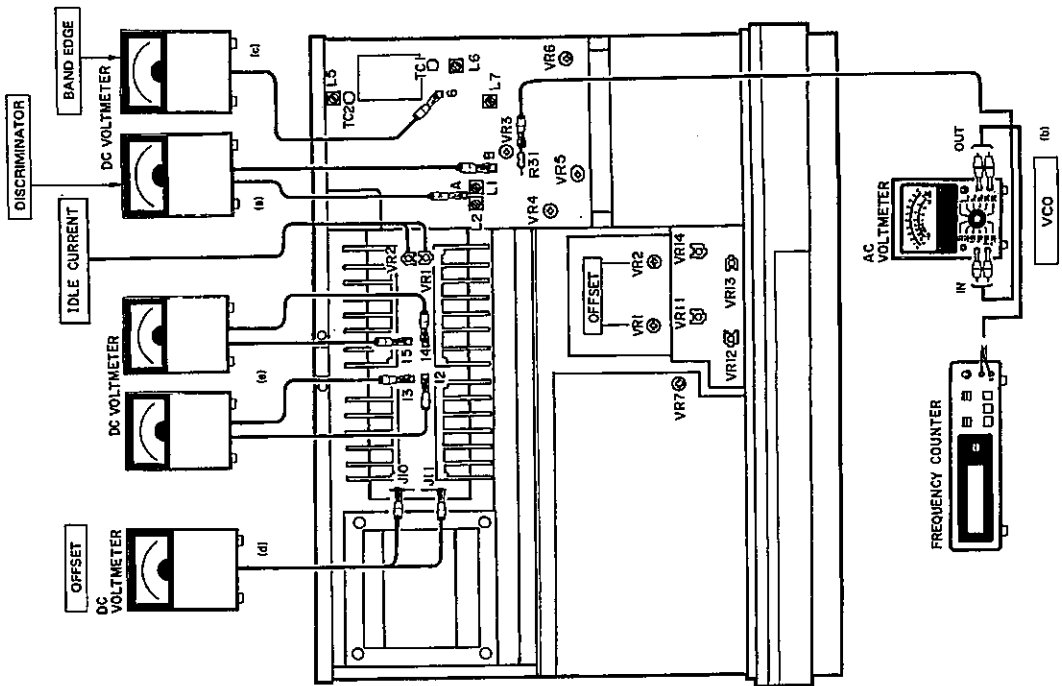
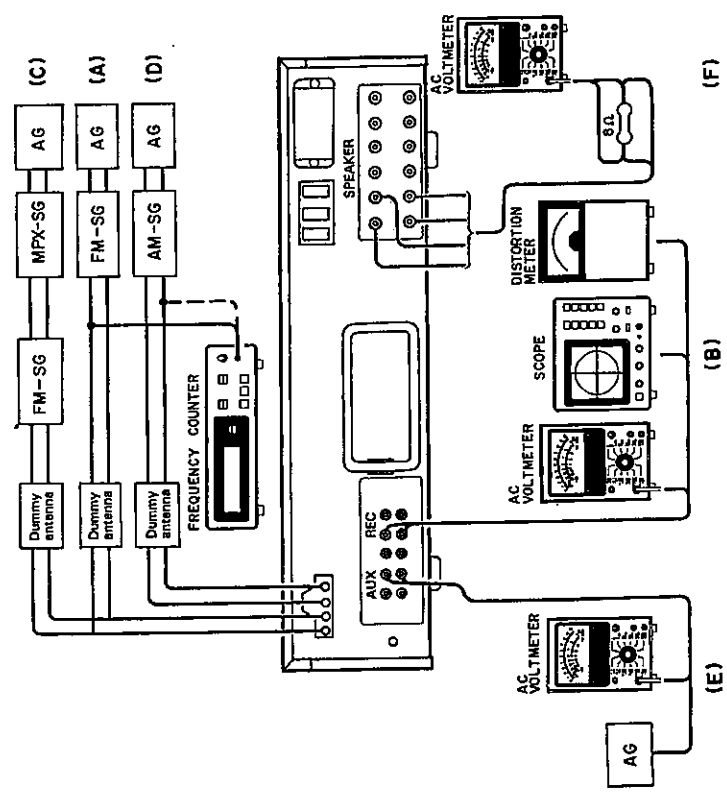

KR-1000/B KR-1000/B

PC BOARD

SWITCH (X13-3160-10) Foil side view

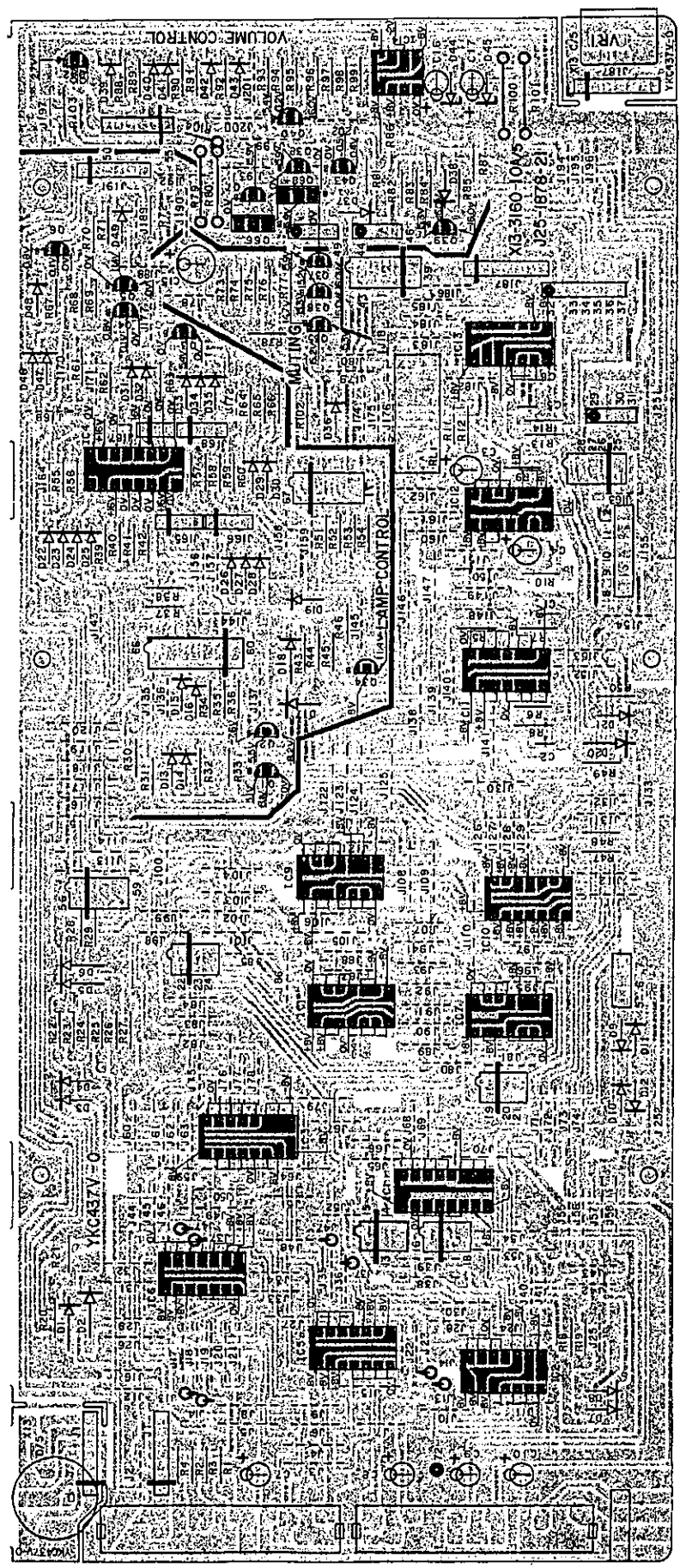

Refer to the schematic diagram for the values of resistors and capacitors.
The PC board drawing is viewing from the side easy to check.

KR-1000/B

AM-FM STEREO RECEIVER

KENWOOD

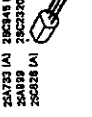
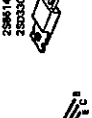
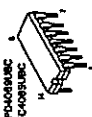
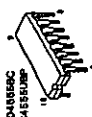
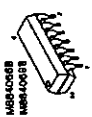
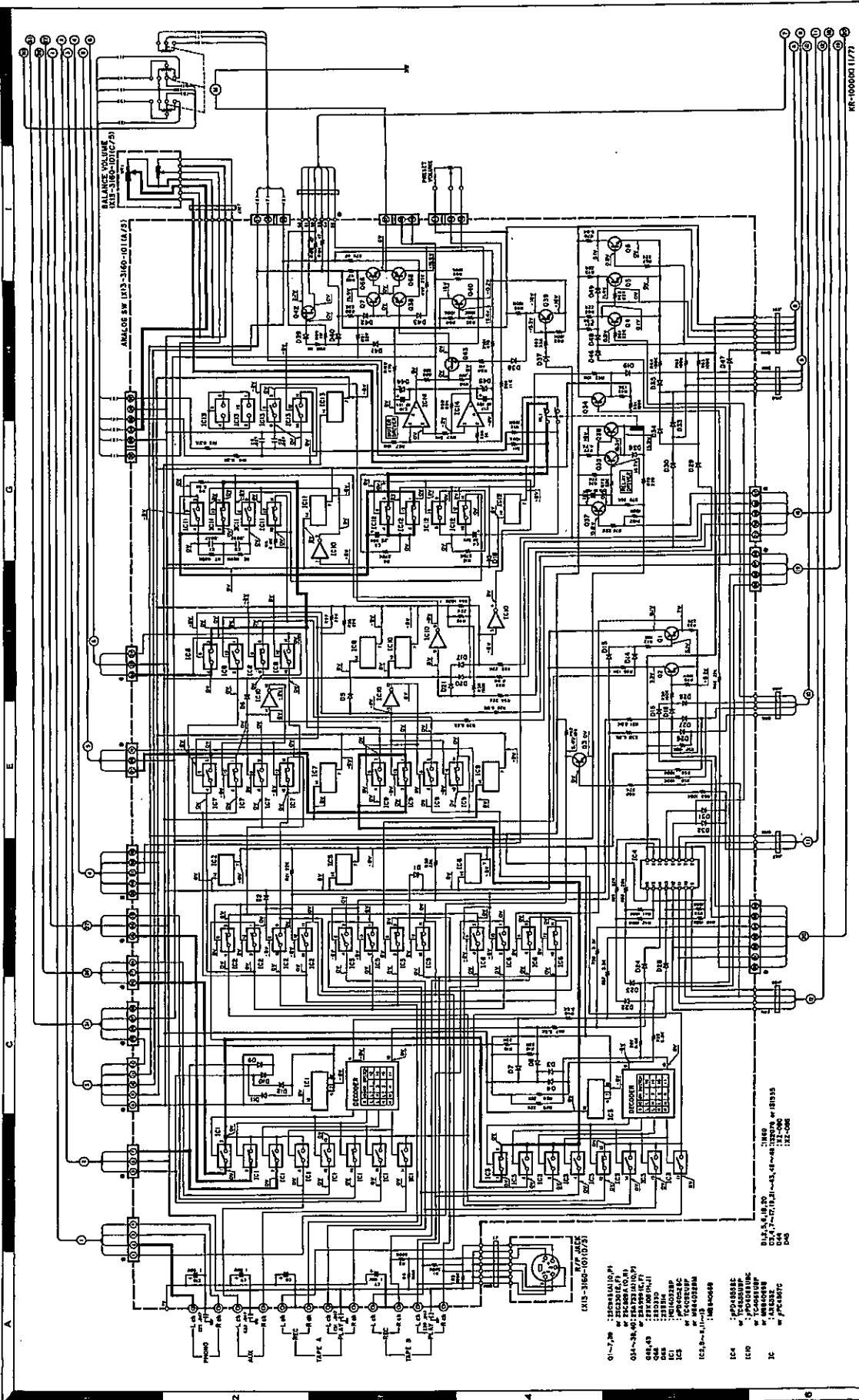

2N4301 (A) 2N4302 (A)
2N4303 (A) 2N4304 (A)
2N4305 (A) 2N4306 (A)
2N4307 (A) 2N4308 (A)
2N4309 (A) 2N4310 (A)

2N4301
2N4302
2N4303
2N4304
2N4305
2N4306
2N4307
2N4308
2N4309
2N4310

2N4301
2N4302
2N4303
2N4304
2N4305
2N4306
2N4307
2N4308
2N4309
2N4310

2N4301
2N4302
2N4303
2N4304
2N4305
2N4306
2N4307
2N4308
2N4309
2N4310

2N4301
2N4302
2N4303
2N4304
2N4305
2N4306
2N4307
2N4308
2N4309
2N4310

2N4301
2N4302
2N4303
2N4304
2N4305
2N4306
2N4307
2N4308
2N4309
2N4310

2N4301
2N4302
2N4303
2N4304
2N4305
2N4306
2N4307
2N4308
2N4309
2N4310

KR-1000/B KR-1000/B

PC BOARD

PRE AMP (X08-1870-10) Component side view

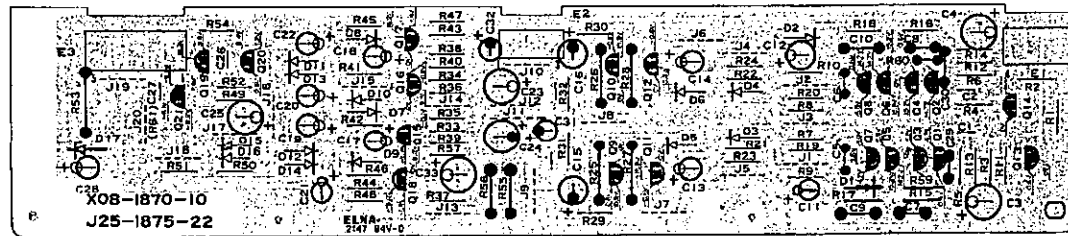

tone AMP (X11-1670-10) Component side view

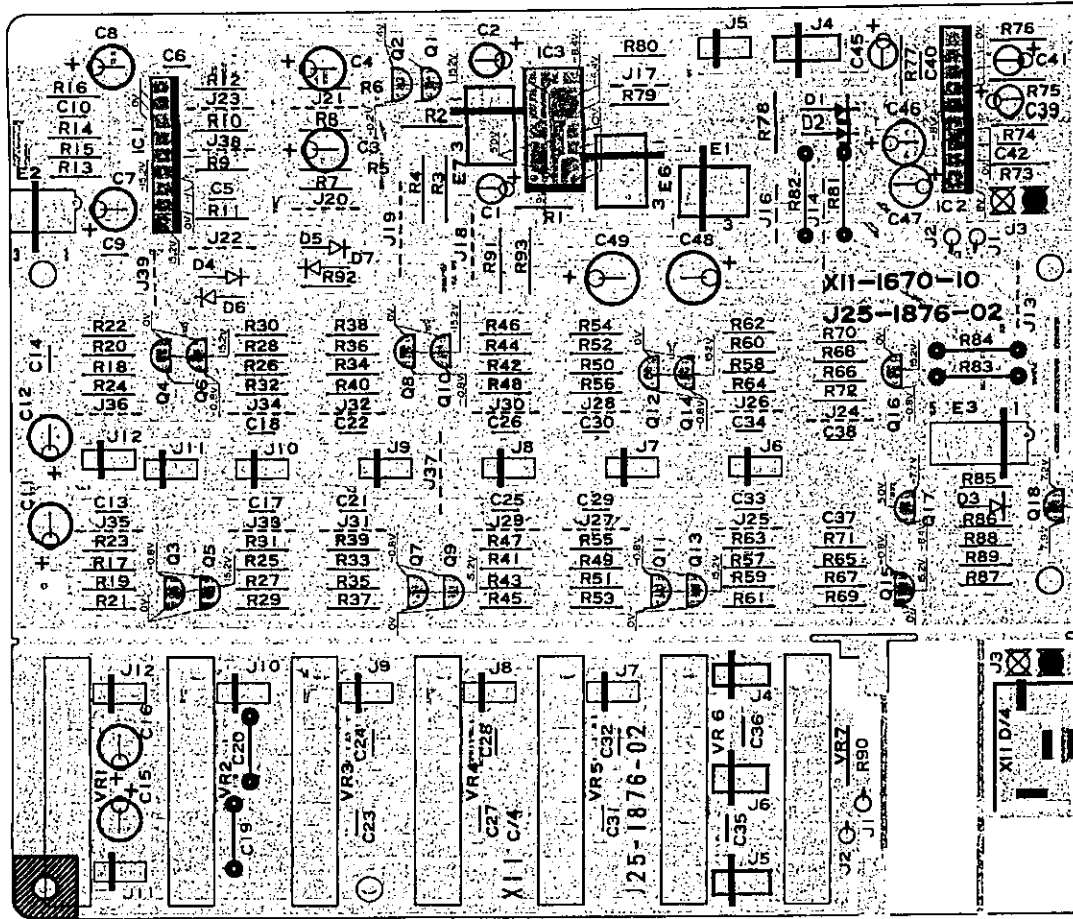

Refer to the schematic diagram for the values of resistors and capacitors.
The PC board drawing is viewing from the side easy to check.

KR-1000/B

AM-FM STEREO RECEIVER

KENWOOD

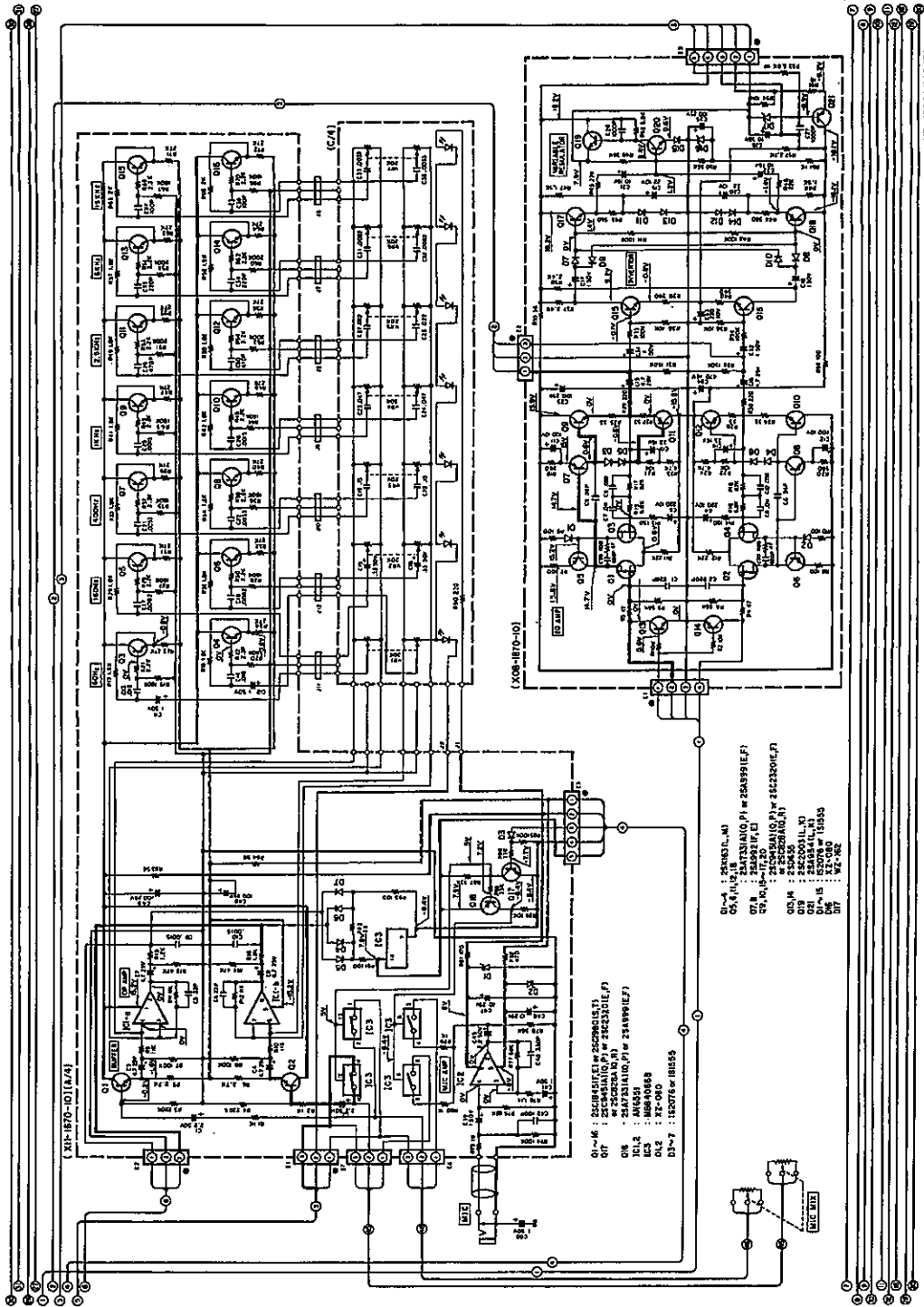

- 25A725 (A)
- 25C038 (A)
- 25C048 (A)
- 25C058 (A)
- 25A085 (A)
- 25A095 (A)
- 25A105 (A)
- 25A115 (A)
- 25A125 (A)
- 25A135 (A)
- 25A145 (A)
- 25A155 (A)
- 25A165 (A)
- 25A175 (A)
- 25A185 (A)
- 25A195 (A)
- 25A205 (A)
- 25A215 (A)
- 25A225 (A)
- 25A235 (A)
- 25A245 (A)
- 25A255 (A)
- 25A265 (A)
- 25A275 (A)
- 25A285 (A)
- 25A295 (A)
- 25A305 (A)
- 25A315 (A)
- 25A325 (A)
- 25A335 (A)
- 25A345 (A)
- 25A355 (A)
- 25A365 (A)
- 25A375 (A)
- 25A385 (A)
- 25A395 (A)
- 25A405 (A)
- 25A415 (A)
- 25A425 (A)
- 25A435 (A)
- 25A445 (A)
- 25A455 (A)
- 25A465 (A)
- 25A475 (A)
- 25A485 (A)
- 25A495 (A)
- 25A505 (A)
- 25A515 (A)
- 25A525 (A)
- 25A535 (A)
- 25A545 (A)
- 25A555 (A)
- 25A565 (A)
- 25A575 (A)
- 25A585 (A)
- 25A595 (A)
- 25A605 (A)
- 25A615 (A)
- 25A625 (A)
- 25A635 (A)
- 25A645 (A)
- 25A655 (A)
- 25A665 (A)
- 25A675 (A)
- 25A685 (A)
- 25A695 (A)
- 25A705 (A)
- 25A715 (A)
- 25A725 (A)
- 25A735 (A)
- 25A745 (A)
- 25A755 (A)
- 25A765 (A)
- 25A775 (A)
- 25A785 (A)
- 25A795 (A)
- 25A805 (A)
- 25A815 (A)
- 25A825 (A)
- 25A835 (A)
- 25A845 (A)
- 25A855 (A)
- 25A865 (A)
- 25A875 (A)
- 25A885 (A)
- 25A895 (A)
- 25A905 (A)
- 25A915 (A)
- 25A925 (A)
- 25A935 (A)
- 25A945 (A)
- 25A955 (A)
- 25A965 (A)
- 25A975 (A)
- 25A985 (A)
- 25A995 (A)
- 25B005 (A)
- 25B015 (A)
- 25B025 (A)
- 25B035 (A)
- 25B045 (A)
- 25B055 (A)
- 25B065 (A)
- 25B075 (A)
- 25B085 (A)
- 25B095 (A)
- 25B105 (A)
- 25B115 (A)
- 25B125 (A)
- 25B135 (A)
- 25B145 (A)
- 25B155 (A)
- 25B165 (A)
- 25B175 (A)
- 25B185 (A)
- 25B195 (A)
- 25B205 (A)
- 25B215 (A)
- 25B225 (A)
- 25B235 (A)
- 25B245 (A)
- 25B255 (A)
- 25B265 (A)
- 25B275 (A)
- 25B285 (A)
- 25B295 (A)
- 25B305 (A)
- 25B315 (A)
- 25B325 (A)
- 25B335 (A)
- 25B345 (A)
- 25B355 (A)
- 25B365 (A)
- 25B375 (A)
- 25B385 (A)
- 25B395 (A)
- 25B405 (A)
- 25B415 (A)
- 25B425 (A)
- 25B435 (A)
- 25B445 (A)
- 25B455 (A)
- 25B465 (A)
- 25B475 (A)
- 25B485 (A)
- 25B495 (A)
- 25B505 (A)
- 25B515 (A)
- 25B525 (A)
- 25B535 (A)
- 25B545 (A)
- 25B555 (A)
- 25B565 (A)
- 25B575 (A)
- 25B585 (A)
- 25B595 (A)
- 25B605 (A)
- 25B615 (A)
- 25B625 (A)
- 25B635 (A)
- 25B645 (A)
- 25B655 (A)
- 25B665 (A)
- 25B675 (A)
- 25B685 (A)
- 25B695 (A)
- 25B705 (A)
- 25B715 (A)
- 25B725 (A)
- 25B735 (A)
- 25B745 (A)
- 25B755 (A)
- 25B765 (A)
- 25B775 (A)
- 25B785 (A)
- 25B795 (A)
- 25B805 (A)
- 25B815 (A)
- 25B825 (A)
- 25B835 (A)
- 25B845 (A)
- 25B855 (A)
- 25B865 (A)
- 25B875 (A)
- 25B885 (A)
- 25B895 (A)
- 25B905 (A)
- 25B915 (A)
- 25B925 (A)
- 25B935 (A)
- 25B945 (A)
- 25B955 (A)
- 25B965 (A)
- 25B975 (A)
- 25B985 (A)
- 25B995 (A)
- 25C005 (A)
- 25C015 (A)
- 25C025 (A)
- 25C035 (A)
- 25C045 (A)
- 25C055 (A)
- 25C065 (A)
- 25C075 (A)
- 25C085 (A)
- 25C095 (A)
- 25C105 (A)
- 25C115 (A)
- 25C125 (A)
- 25C135 (A)
- 25C145 (A)
- 25C155 (A)
- 25C165 (A)
- 25C175 (A)
- 25C185 (A)
- 25C195 (A)
- 25C205 (A)
- 25C215 (A)
- 25C225 (A)
- 25C235 (A)
- 25C245 (A)
- 25C255 (A)
- 25C265 (A)
- 25C275 (A)
- 25C285 (A)
- 25C295 (A)
- 25C305 (A)
- 25C315 (A)
- 25C325 (A)
- 25C335 (A)
- 25C345 (A)
- 25C355 (A)
- 25C365 (A)
- 25C375 (A)
- 25C385 (A)
- 25C395 (A)
- 25C405 (A)
- 25C415 (A)
- 25C425 (A)
- 25C435 (A)
- 25C445 (A)
- 25C455 (A)
- 25C465 (A)
- 25C475 (A)
- 25C485 (A)
- 25C495 (A)
- 25C505 (A)
- 25C515 (A)
- 25C525 (A)
- 25C535 (A)
- 25C545 (A)
- 25C555 (A)
- 25C565 (A)
- 25C575 (A)
- 25C585 (A)
- 25C595 (A)
- 25C605 (A)
- 25C615 (A)
- 25C625 (A)
- 25C635 (A)
- 25C645 (A)
- 25C655 (A)
- 25C665 (A)
- 25C675 (A)
- 25C685 (A)
- 25C695 (A)
- 25C705 (A)
- 25C715 (A)
- 25C725 (A)
- 25C735 (A)
- 25C745 (A)
- 25C755 (A)
- 25C765 (A)
- 25C775 (A)
- 25C785 (A)
- 25C795 (A)
- 25C805 (A)
- 25C815 (A)
- 25C825 (A)
- 25C835 (A)
- 25C845 (A)
- 25C855 (A)
- 25C865 (A)
- 25C875 (A)
- 25C885 (A)
- 25C895 (A)
- 25C905 (A)
- 25C915 (A)
- 25C925 (A)
- 25C935 (A)
- 25C945 (A)
- 25C955 (A)
- 25C965 (A)
- 25C975 (A)
- 25C985 (A)
- 25C995 (A)

KR-1000/B KR-1000/B

PC BOARD

PUSH BUTTON (X13-3230-10) Foil side view

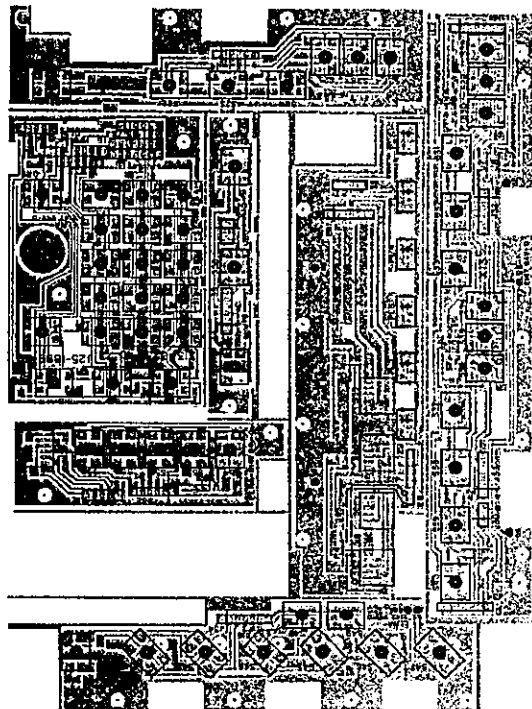

SWITCH (X13-3160-10) Component side view

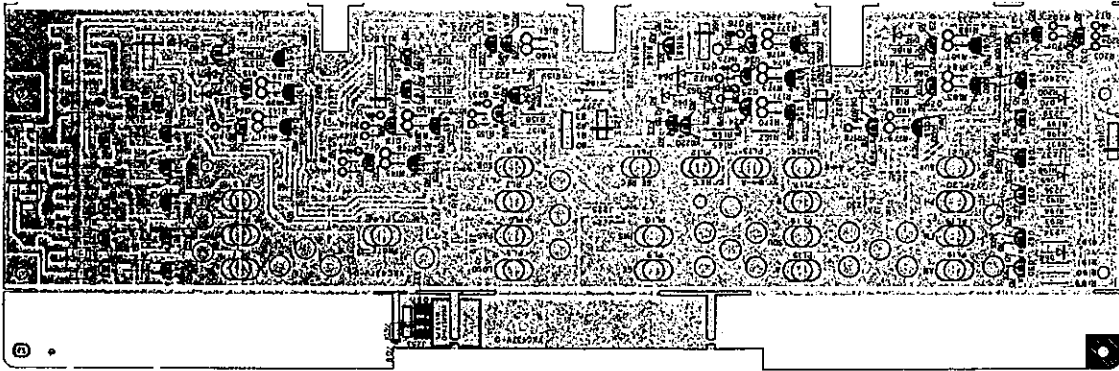

BUZZER (X13-4300-10) Component side view

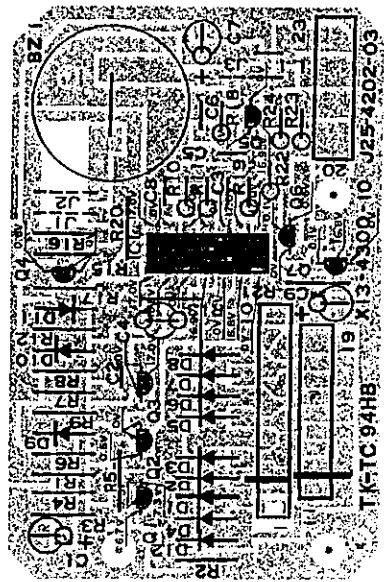

Refer to the schematic diagram for the values of resistors and capacitors.
The PC board drawing is viewing from the side easy to check.

KR-1000/B

AM-FM STEREO RECEIVER

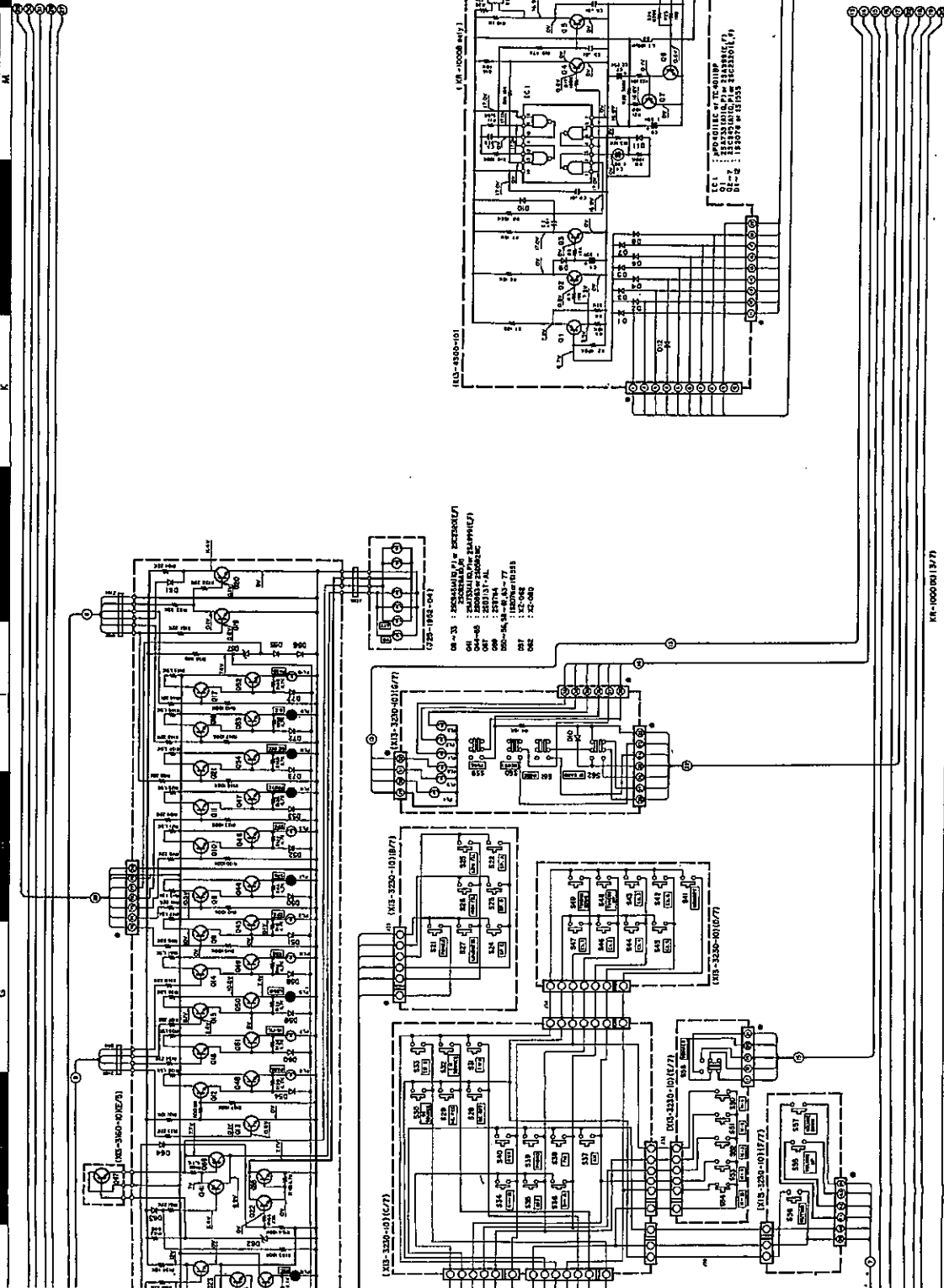

KR-1000/B

KR-1000/B(11/71)

TUNER (X05-2000-10) Component side view

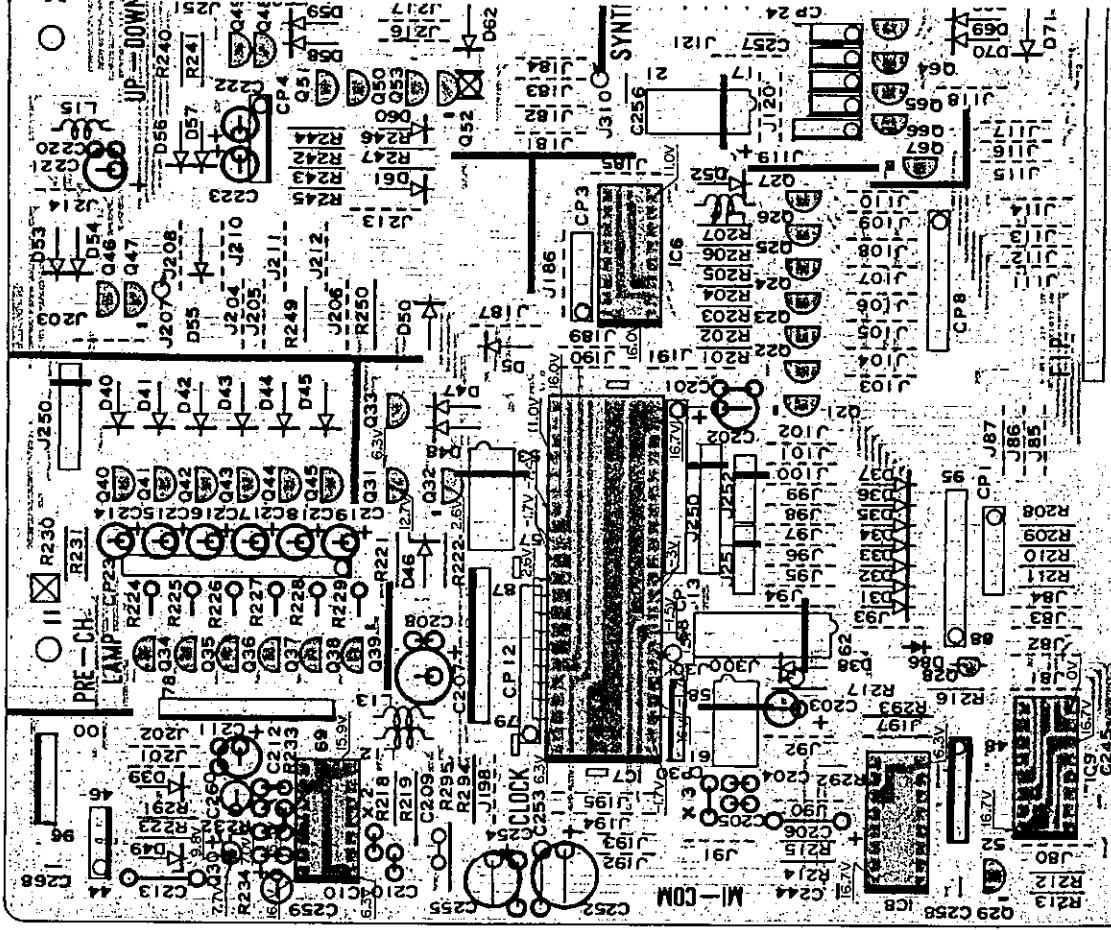

KR-1000/B KR-1000/B PC BOARD

TUNER (X05-2000-10) Component side view

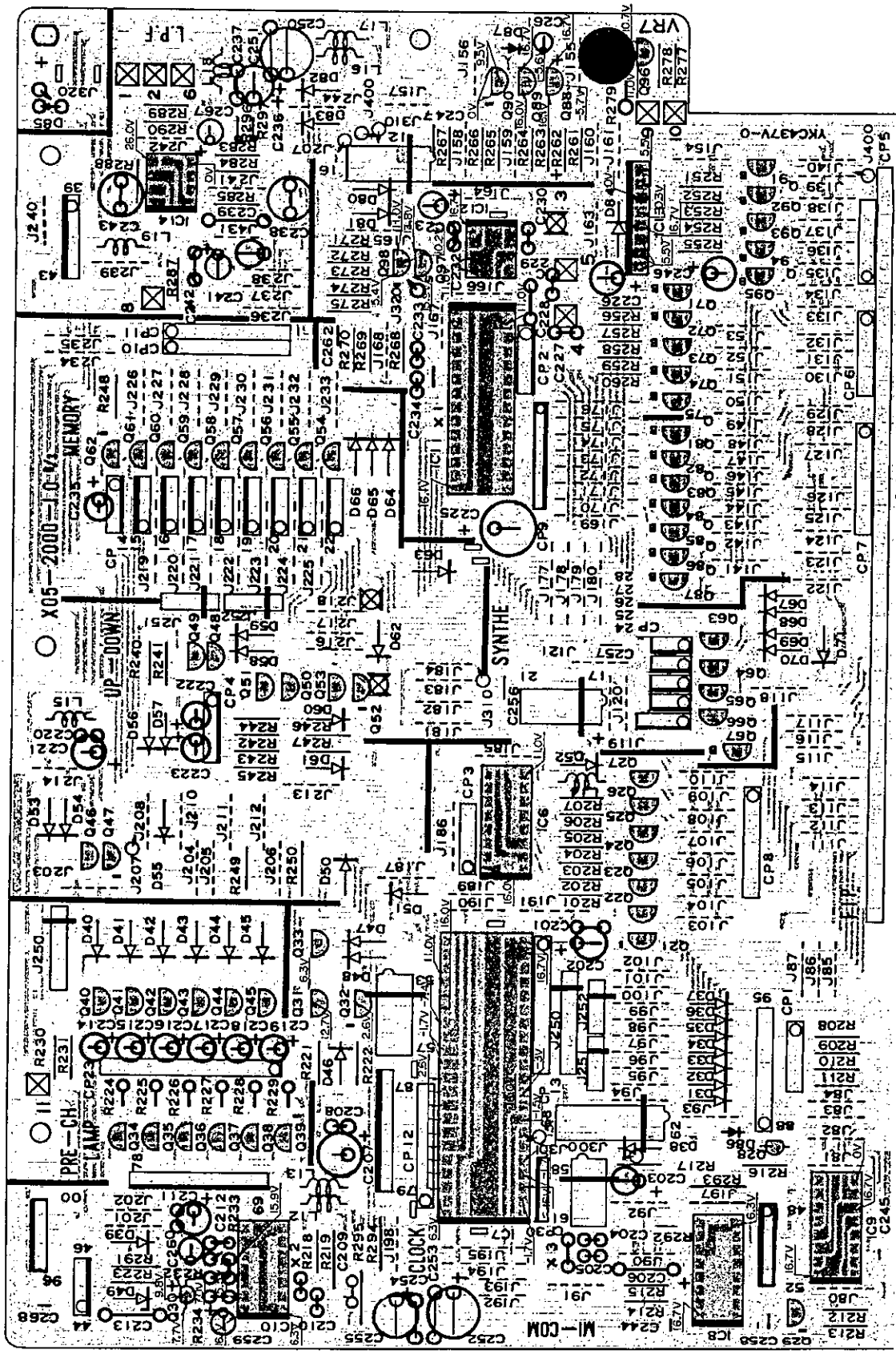

Refer to the schematic diagram for the values of resistors and capacitors.
The PC board drawing is viewing from the side easy to check.

PC BOARD

TUNER (X05-2000-10) Component side view

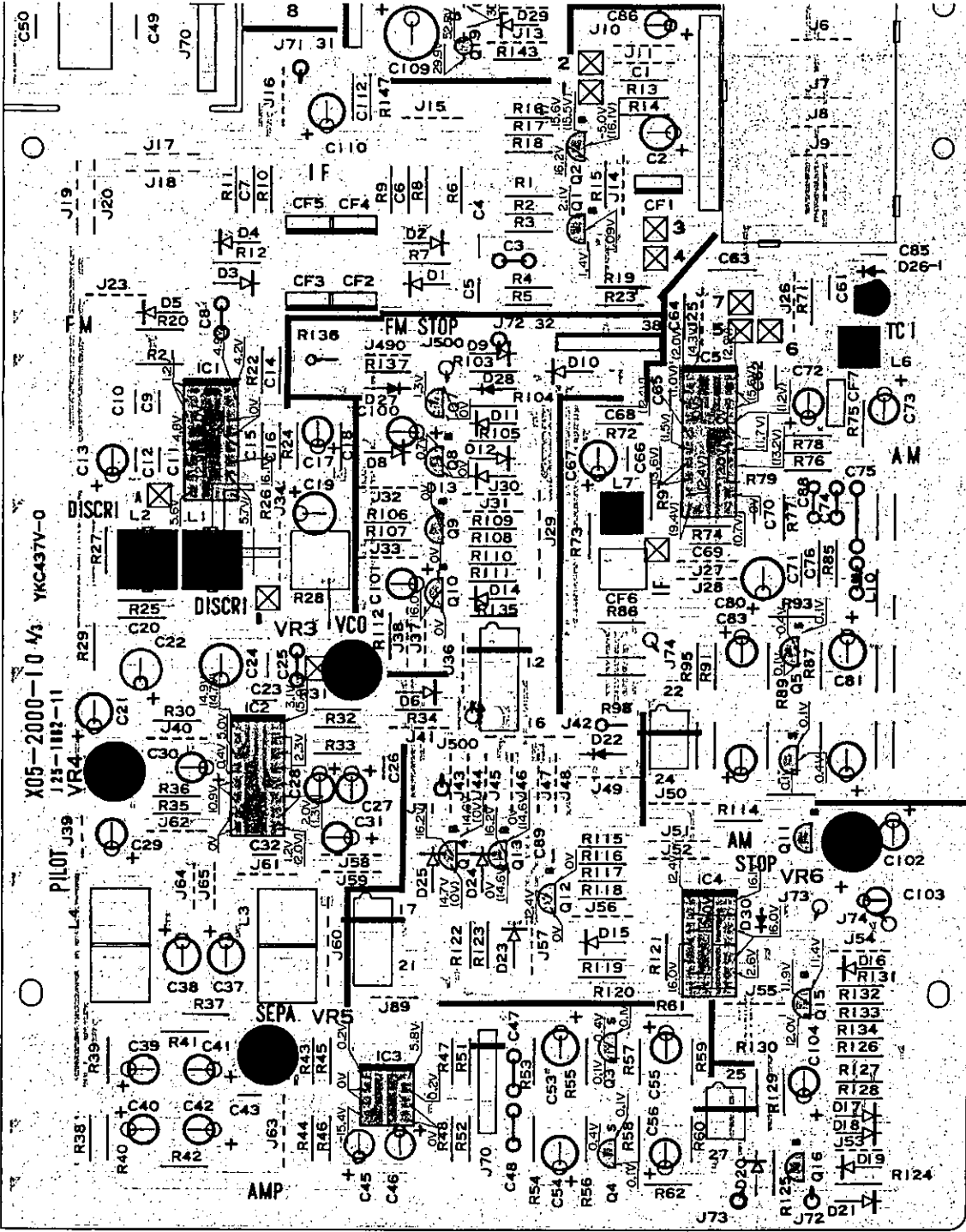

KR-1000/B KR-1000/B

PC BOARD

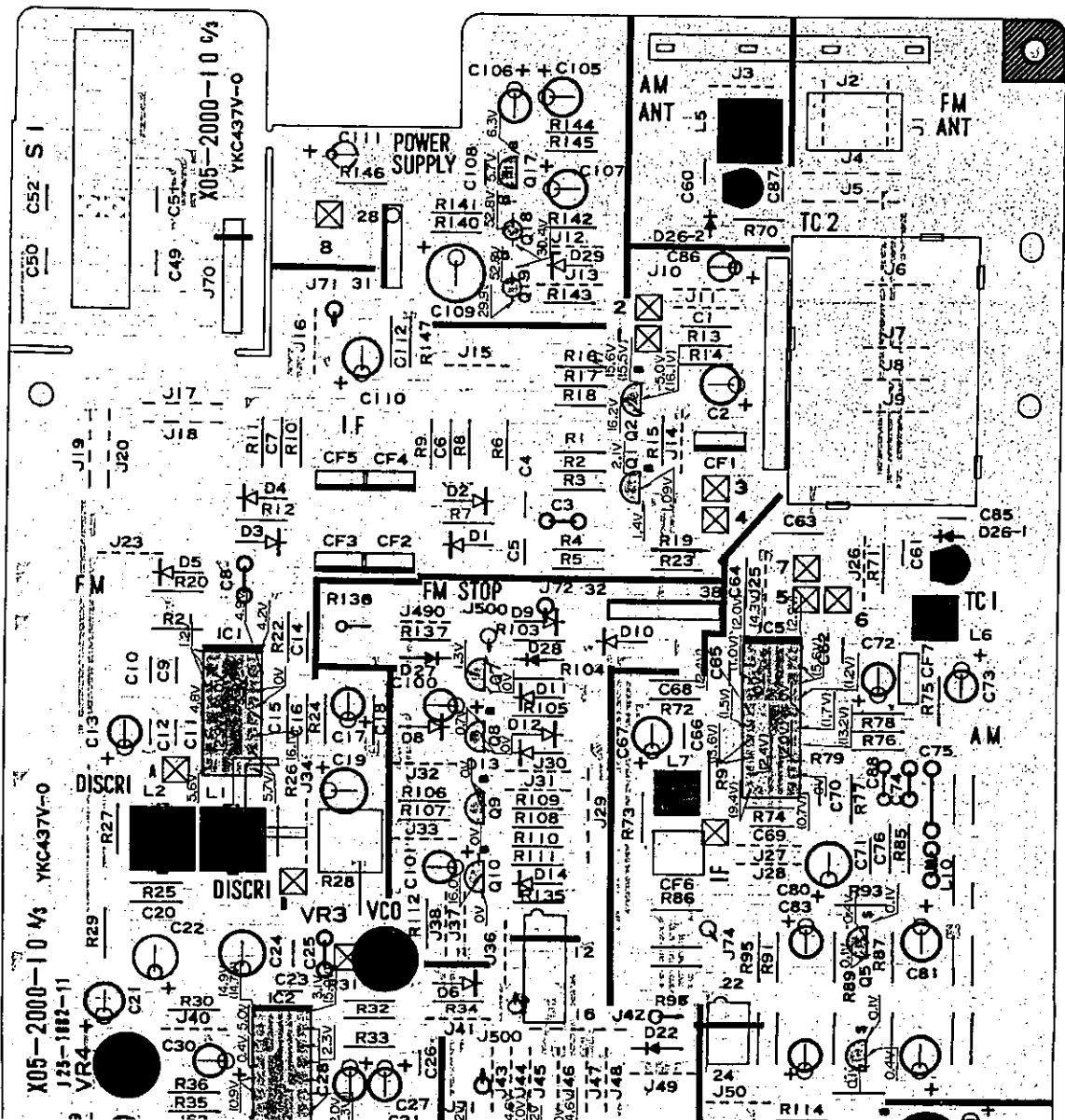

Refer to the schematic diagram for the values of resistors and capacitors. The PC board drawing is viewing from the side easy to check.

KR-1000/B

AM-FM STEREO RECEIVER

KENWOOD

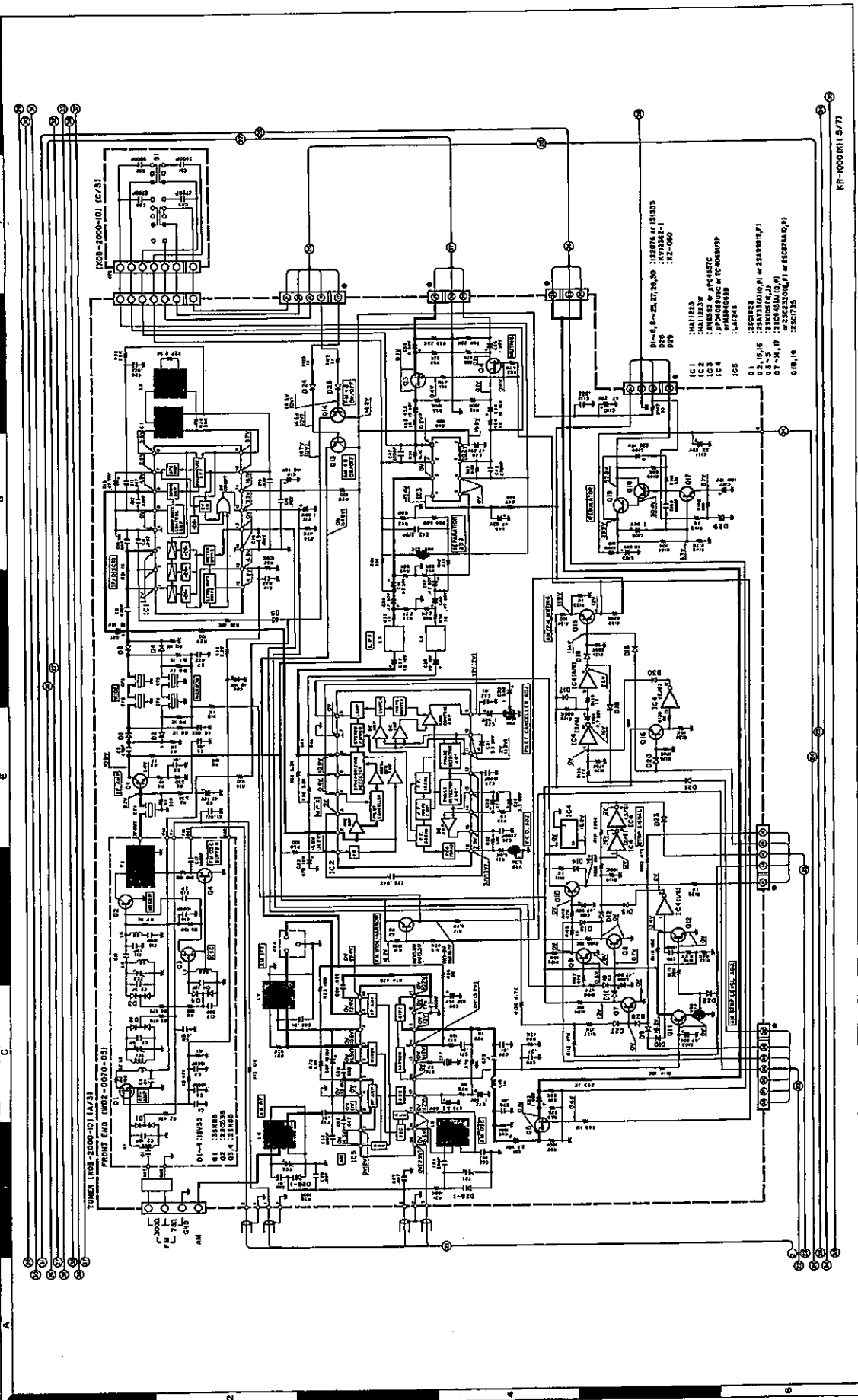

KR-1000/B KR-1000/B

PC BOARD

POWER SUPPLY (X00-2160-10) Foil side view

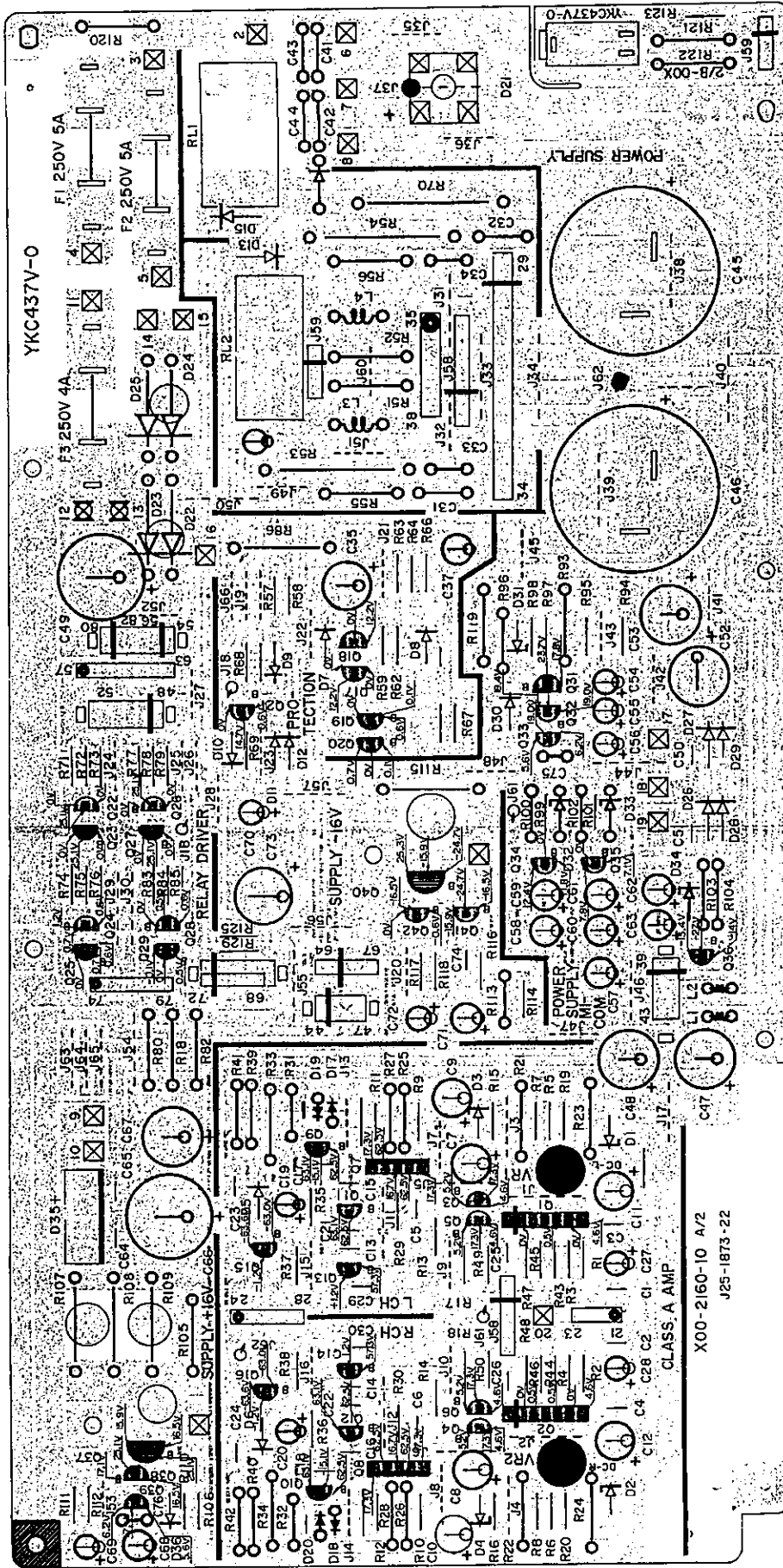

Refer to the schematic diagram for the values of resistors and capacitors.
The PC board drawing is viewing from the side as *sy* to check.

KR-1000/B

AM-FM STEREO RECEIVER

KENWOOD

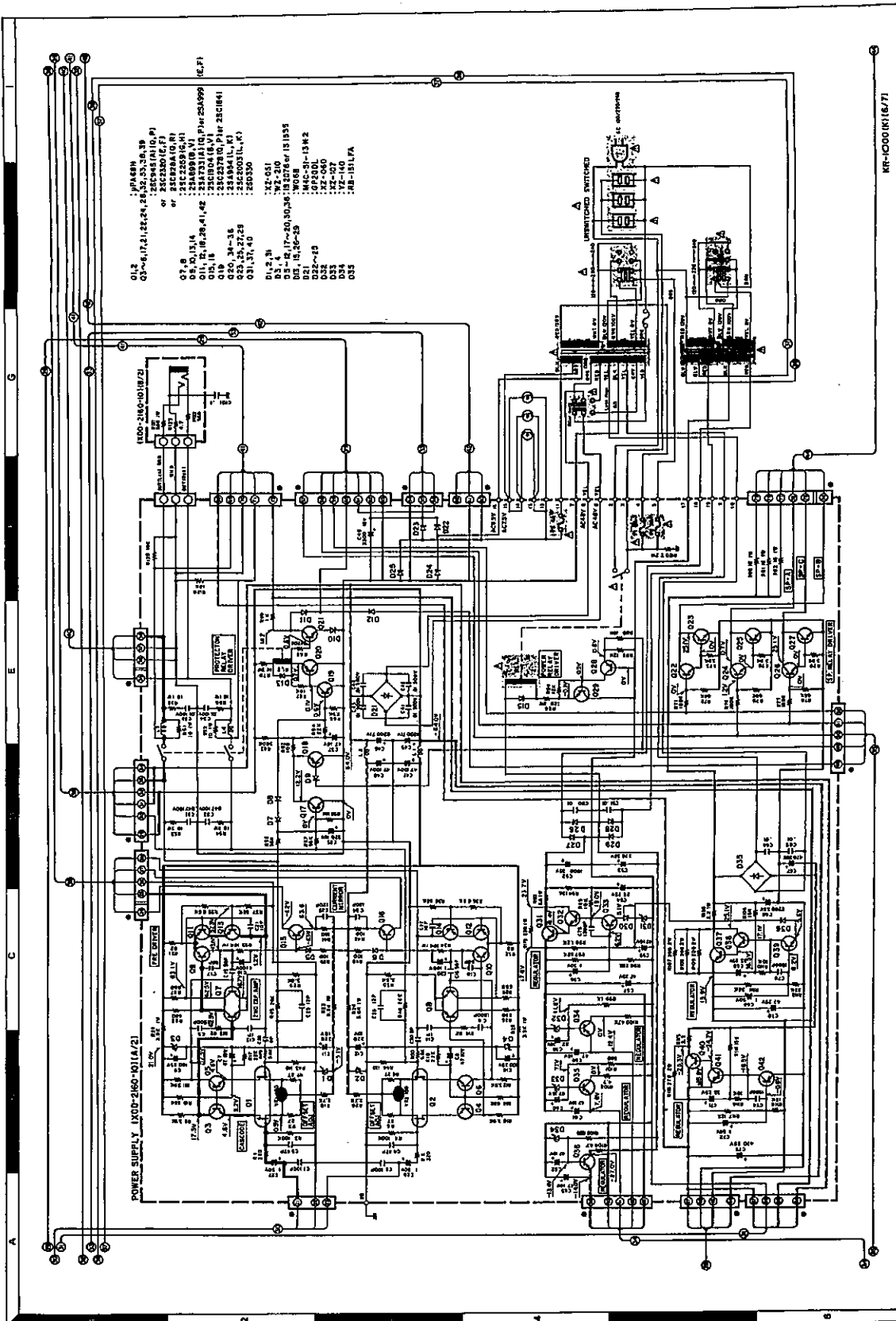

KR-1000 (K16/71)

- 25A3703 (A)
- 25A3889
- 25A3954
- 25C2320
- 25C2328A
- 25C2328B
- 25C2346 (A)
- 25C21841
- 25C2320
- 25C21804
- 25C23278
- 25C2328A
- 25C2346 (A)
- 25C21841



P1A88N
 25C2320
 25A3889
 25C21804
 25C23278
 25C2328A
 25C2346 (A)
 25C21841

KR-1000/B KR-1000/B

PC BOARD

PC BOARD (X11-1670-10) Component side view

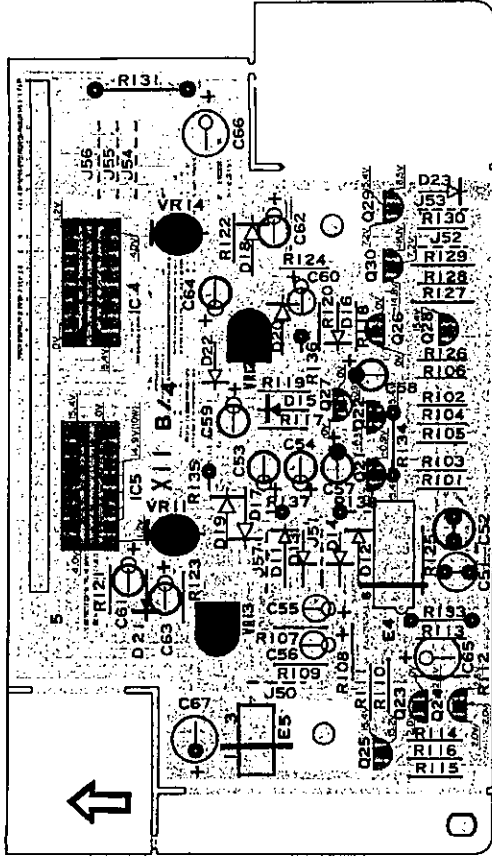

MAIN AMP (X07-1900-10) Foil side view

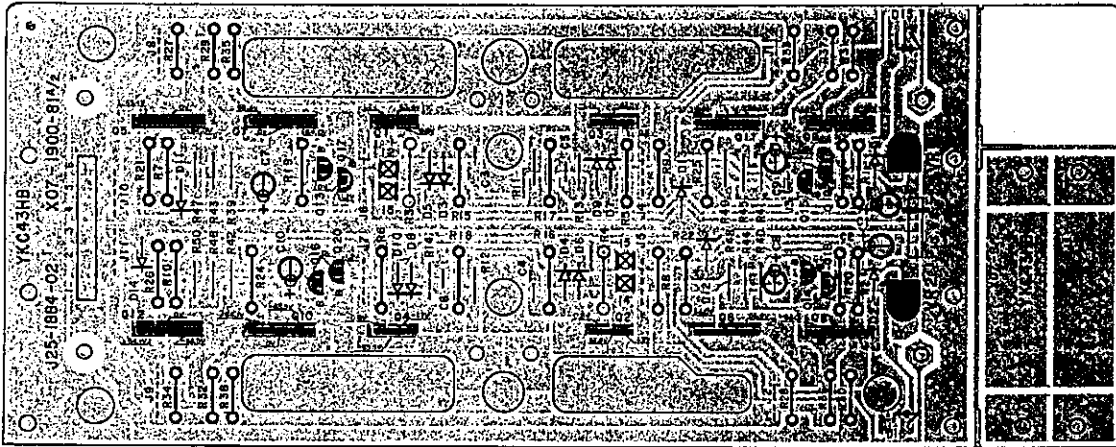

SPEAKER (X13-3150-10) Foil side view

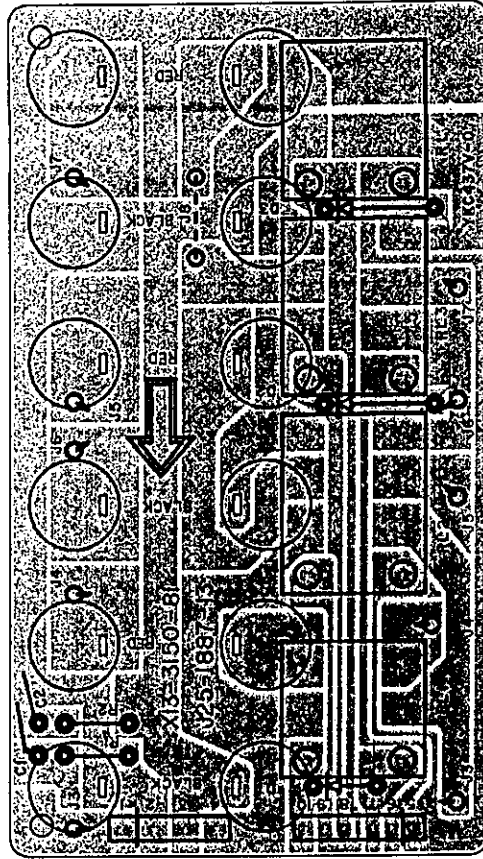

Refer to the schematic diagram for the values of resistors and capacitors.
The PC board drawing is viewing from the side easy ID check.

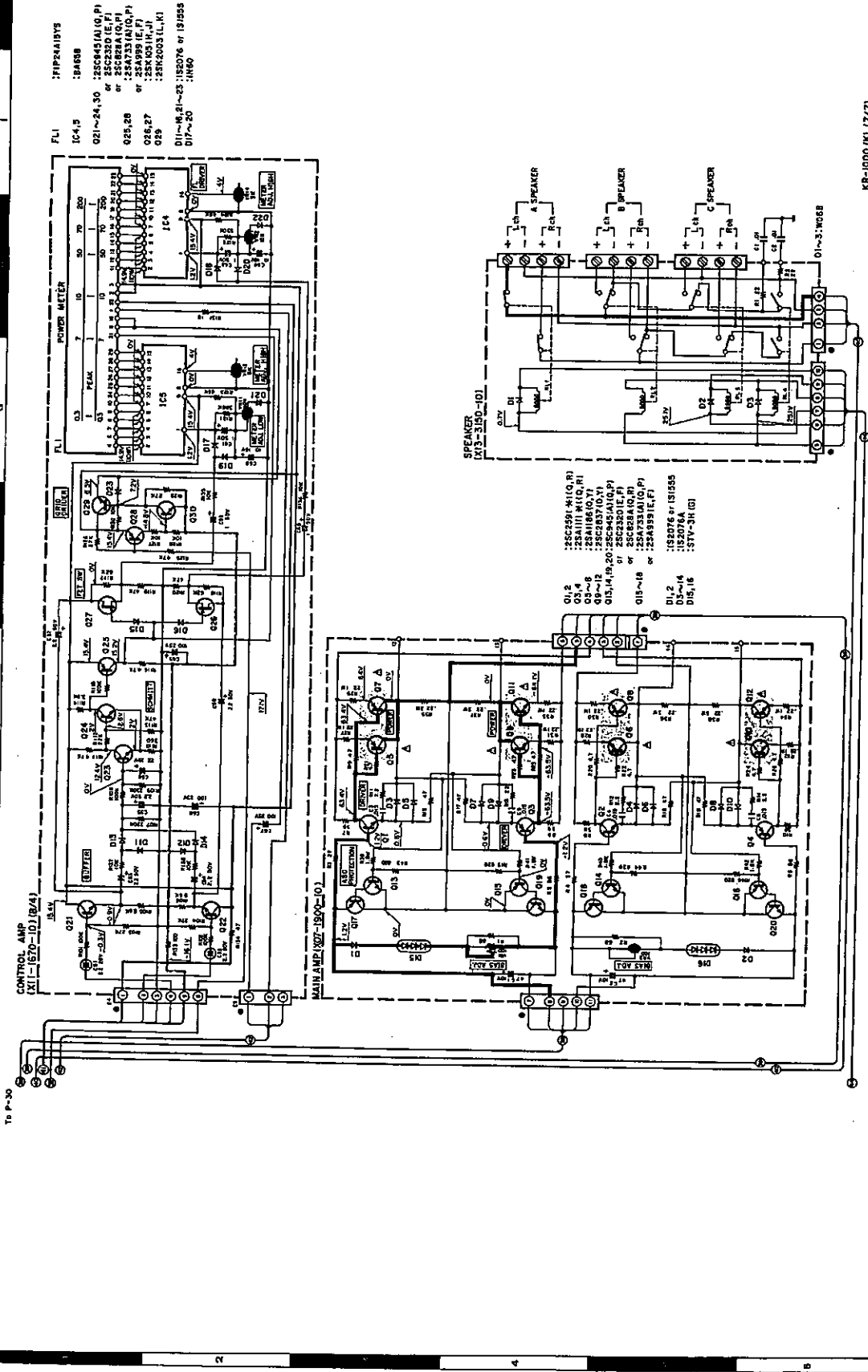

- FL1 : P1PRA1915Y5
IC4,5 : 184688
021~24,30 : 25C645 (A1,Q,P)
or 25C230 (E,F)
025,28 : 25C824 (Q,P)
or 25A99 (E,F)
026,27 : 25K103 (R,J)
029 : 25K2003 (L,K)
011~14,21~23 : 15D076 or 151555
017~20 : 1N460

- 01,2 : 25C2301 (M1,Q,R)
03,4 : 25N118 (M1,Q)
05~12 : 25C2337 (O,Y)
013,14,19,20 : 25C345 (A1,Q,P)
or 25C230 (E,F)
015~18 : 25A733 (A1,Q)
or 25A939 (E,F)
01,2,14 : 15D076 or 151555
015,16 : 3171-31K (Q)

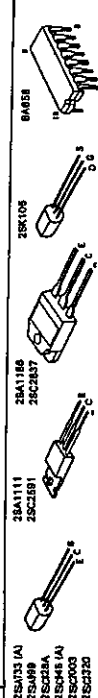

KR-1000 (K) (7/7)

KR-1000/B



AM-FM STEREO RECEIVER

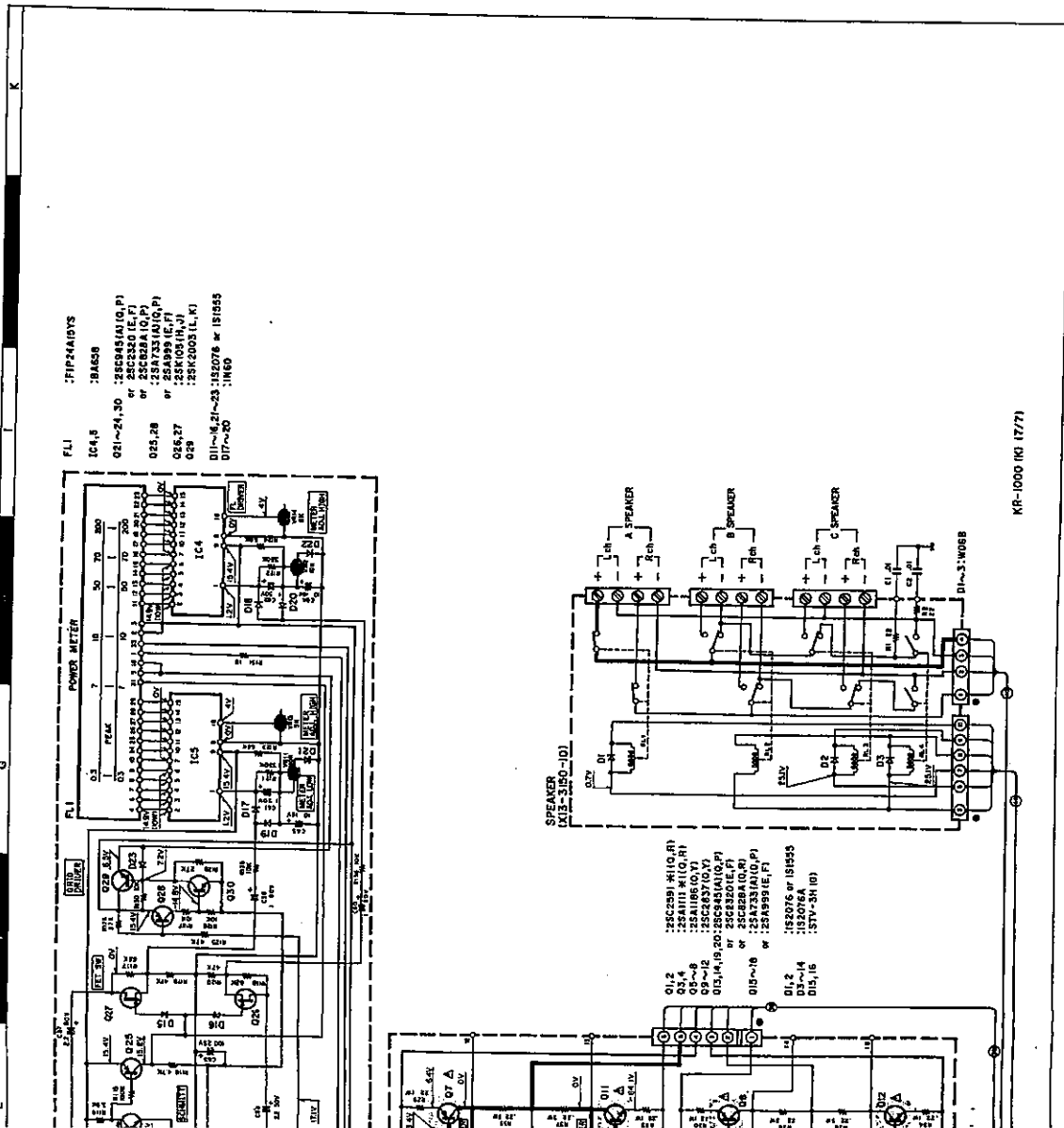

F1: 2F1P24NDYS
 IC4,5: 2BA65B
 021~21,30: 25C645(A)(G,P)
 or 25C645(A)(G,P)
 or 25C638(A)(G,P)
 025,28: 25A733(A)(G,P)
 or 25A999(IC,F)
 026,27: 25K100(H,J)
 028: 25K200(L,K)
 D11~16,21~23: 15Z076 or 15Z555
 017~20: 15ND6

01,2: 25C2391(H)(Q,R)
 02,4: 25A111(H)(G,R)
 03~6: 25A106(O,Y)
 07: 25C2391(H)(Q,R)
 015(A)(B,20): 25C431(A)(G,P)
 or 25C431(A)(G,P)
 015~18: 25C229(A)(Q,R)
 or 25A999(IC,F)
 D1,2: 15Z076 or 15Z555
 D3~14: 15Z076A
 D15,16: 15TV-3M (B)

SPECIFICATIONS

AUDIO SECTION

Power Output
 120 watts* per channel minimum RMS, both channels driven at 8 ohms from 20 Hz to 20,000 Hz with no more than 0.01% total harmonic distortion.

Total Harmonic Distortion (20 Hz to 20,000 Hz from TAPE) read power into 8 ohms: 0.01%
 1 watt power into 8 ohms: 0.005%
Intermodulation Distortion (60 Hz, 7 kHz, 4:1 SMPTE) read power into 8 ohms: 0.005%
Slew Rate: 1.5 V/μsec
Rise Time: 1.2 μsec
Damping Factor: 75
 (at 1 kHz into 8 ohms)
Impedance/Impedance
 PHONO: 2.5 mV/50k ohms
 TAPE, AUX: 2.5 mV/50k ohms

Signal to Noise Ratio (A weighted)
 PHONO: 82 dB for 2.5 mV input
 TAPE, AUX: 105 dB for 150 mV input
MIC: 72 dB for 2.5 mV input
Maximum PHONO Input Level: 150 mV rms, THD 0.03% at 1,000 Hz, 100 Hz
PHONO RIAA Standard
 Curve: 20 Hz to 20,000 Hz ±0.3 dB
TAPE, AUX: 2-Band Multiple Acoustic Compensator
 100 Hz to 10,000 Hz: 1.5 dB
 1 kHz, 2.5 kHz, 5 kHz and 15 kHz: ±10 dB at each frequency
Loadless Control
 (Vd -20 dB)
High Filter: 18 Hz @ 6 dB/oct
Output Level/Impedance: 5 Vrms @ 16 ohms
TAPE REC Out (Pin): 150 mV/16 ohms (DIN)
 30 mV/80k ohms

*Measured pursuant to Federal Trade Commission's Trade Regulation rule on Power Output Claims for Amplifier in U.S.A.

CAUTION: For continued safety, replace safety critical components only with manufacturer's recommended parts (refer to parts list). **Δ** Indicates safety critical components. To reduce the risk of electric shock, leakage-current or resistance measurements shall be carried out (exposed parts are acceptably insulated from the supply circuit) before the appliance is returned to the customer.
 DC voltages are as measured with a high impedance voltmeter. Values may vary slightly due to variations between individual instrument units.

Les tensions c.a.c. doivent être mesurées avec un voltmètre à haute impédance. Les valeurs peuvent différer légèrement du fait des variations inhérentes aux appareils et aux instruments de mesure individuels.
 Die angegebenen Gleichspannungswerte wurden mit einem hochohmigen Spannungsmesser gemessen. Dabei schwanken die Meßwerte aufgrund von Unterschieden zwischen einzelnen Instrumenten oder Geräten u.U. geringfügig.

FM TUNER SECTION

Usable Sensitivity: 10.3 dBf (11.6 μV)
50 dB Quieting Sensitivity: 18.1 dBf (13.5 μV)
Mono: 35.6 dBf (135 μV)
Stereo: 35.6 dBf (135 μV)
Signal to Noise Ratio at 65 dB: 76 dB
Mono: 70 dB
Stereo: 70 dB
Total Harmonic Distortion at 1,000 Hz (w/d): 0.00%
Mono: 0.01%
Stereo: 0.1%

Frequency Response: 30 Hz to 15,000 Hz +0.5 dB
 -1.0 dB
Capture Ratio: 1.0 dB
Image Rejection Ratio: 80 dB (88 MHz)
Spurious Response Ratio: 30 dB (98 MHz)
IF Response Ratio: 100 dB (98 MHz)
Alternate Channel Selectivity
 WIDE CH: 30 dB at 3,000 kHz
 NARROW CH: 60 dB at 3,000 kHz
AM Suppression Ratio
 Stereo Suppression Ratio (width)
 at 1,000 Hz: 30 dB
 at 50 Hz to 10,000 Hz: 37 dB
Subcarrier Product Ratio: 85 dB
Antenna Impedance: 300 ohms balanced and 75 ohms unbalanced
FM Frequency Range: 88 MHz to 108 MHz

AM TUNER SECTION

Usable Sensitivity: 14 μV
Signal to Noise Ratio: 50 dB
Image Rejection: 40 dB
Selectivity: 45 dB
GENERAL
Power Consumption
 700 watts at full power
 120 watts at no signal
 4.1 watts at power switch off
Switched 2, Unswitched 1
W: 550 mm (21 1/2")
H: 155 mm (6 1/8")
D: 443 mm (17 7/16")
Net Weight: 19 (52.7 lb)
Gross Weight: 18.5 kg (40.8 lb)

AC Outlet
Dimensions
Net Weight
Gross Weight

Konsumiert folgende à policy of continuous advancements in development. For this reason specifications may be changed without notice.
 Kenwood poursuit une politique de progrès constants en ce qui concerne le développement. Pour cette raison, les spécifications sont sujettes à modifications sans préavis.
 Kenwood unterzieht sich fortwährend der Entwicklung in diesem Bereich. Aus diesem Grund können die technischen Daten jederzeit verändert werden.

PARTS LIST

* New Parts... Parts No. are not supplied... Les articles non mentionnés dans le Parts No. ne sont pas fournis.

Table with 6 columns: Ref. No., Address, Parts No., Description, Destination, Remarks. Lists various electrical components like BELT, HERICAL GEAR, PHONE JACK, etc.

E: Scandinavia & Europe... S: South Africa... T: England... X: Australia... P: Canada... A: Indicates safety critical components.

PARTS LIST

* New Parts... Parts No. are not supplied... Les articles non mentionnés dans le Parts No. ne sont pas fournis.

Table with 6 columns: Ref. No., Address, Parts No., Description, Destination, Remarks. Lists various mechanical and electrical components like METALLIC CABINET, FRONT GLASS, LAMP, etc.

E: Scandinavia & Europe... S: South Africa... T: England... X: Australia... P: Canada... A: Indicates safety critical components.

KR-1000/B KR-1000/B

PARTS LIST

* New Parts
 Parts without Part No. are not supplied.
 Les articles non mentionnés dans le Parts No. ne sont pas fournis.
 Teile ohne Parts No. werden nicht geliefert.

Ref. No. 参照番号	Address 位置	Part No. 部品番号	Description 部品名 / 規格	Desti- nation 仕	Re- marks 備考
54	36	D14-0065-04	BELT	UEB	
54	36	D16-0071-04	HERICAL GEAR (VOLUME)	UEB	
55	1D	D13-0069-04	AC OUTLET	UEB	
56	1D	E03-0007-05	AC POWER CORD	UEB	
56	1D	E30-0181-05	AC POWER CORD	UEB	
56	1D	E30-0580-05	AC POWER CORD	UEB	
56	1D	E30-0812-05	AC POWER CORD	UEB	
E1	3F	E11-0088-05	PHONE JACK (MIC)	KNJH	
E1	3F	E11-0089-05	PHONE JACK (MIC)	KNJH	
E1	3F	E11-0124-05	PHONE JACK (MIC)	KNJH	
57	36	G01-0409-04	EXTENSION SPRING	UEB	
-	-	H01-3308-04	ITEM CARTON CASE	UEB	
-	-	H01-3308-04	ITEM CARTON CASE	UEB	
-	-	H01-4800-04	ITEM CARTON CASE	UEB	
-	-	H01-4800-04	ITEM CARTON CASE	UEB	
-	-	H10-1592-01	POLYSTYRENE FRAMED FIXTURE	UEB	
-	-	H10-1593-11	POLYSTYRENE FRAMED FIXTURE	UEB	
-	-	H20-0442-04	PROTECTION COVER	UEB	
-	-	H20-0442-04	PROTECTION COVER	UEB	
-	-	H20-0443-04	PROTECTION COVER	UEB	
-	-	H21-0219-04	PROTECTION SHEET	UEB	
-	-	H25-0078-04	PROTECTION BAG (235X315)	UEB	
58	3C	J02-0101-05	FOOT	UEB	
59	1D	J19-0626-12	ANTENNA HOLDER	UEB	
61	3B	K27-0612-04	KNBB (PDSDE, IF BAND, TUNE, SENS1)	UEB	
61	3B	K27-0612-04	KNBB (PDSDE, IF BAND, TUNE, SENS1)	UEB	
61	3B	K27-0616-04	KNBB (BUTTON)	UEB	
62	3A	K27-0615-04	KNBB (DIMMER)	UEB	
62	3A	K27-0613-04	KNBB (DIMMER)	UEB	
62	3A	K27-1017-04	KNBB (DIMMER)	UEB	
62	3A	K27-1017-04	KNBB (DIMMER)	UEB	
63	3A	K27-0614-04	KNBB (MEMBERY)	UEB	
63	3A	K27-0614-04	KNBB (MEMBERY)	UEB	
63	3A	K27-0614-04	KNBB (MEMBERY)	UEB	
63	3A	K27-1018-04	KNBB (MEMBERY)	UEB	
64	2B	K27-1018-04	KNBB (MEMBERY)	UEB	
64	2B	K27-0615-04	KNBB (G. E.)	UEB	
64	2B	K27-0615-04	KNBB (G. E.)	UEB	
64	2B	K27-1019-04	KNBB (BUTTON) (G. E.)	UEB	
64	2B	K27-1019-04	KNBB (BUTTON) (G. E.)	UEB	
65	2C	K29-0404-14	KNBB (BALANCE MIXING)	UEB	
65	2C	K29-0404-14	KNBB (BALANCE MIXING)	UEB	
65	2C	K29-1305-04	KNBB (BALANCE MIXING)	UEB	
65	2C	K29-1305-04	KNBB (BALANCE MIXING)	UEB	
66	2B	K29-0405-14	KNBB (PRESET)	UEB	
66	2B	K29-0405-14	KNBB (PRESET)	UEB	
66	2B	K29-1394-04	KNBB (PRESET)	UEB	
67	3B	K29-0406-13	KNBB ASSY (VOLUME)	UEB	

E: Scandinavia & Europe H: Audio Club K: USA
 S: South Africa T: England U: (P) (W) East: Hawaii
 (UE): AMFES(Europe) X: Australia M: Other Areas J: M. U. E. UEB: KR-1000B
 P: Canada Δ indicates safety critical components.

PARTS LIST

* New Parts
 Parts without Part No. are not supplied.
 Les articles non mentionnés dans le Parts No. ne sont pas fournis.
 Teile ohne Parts No. werden nicht geliefert.

Ref. No. 参照番号	Address 位置	Part No. 部品番号	Description 部品名 / 規格	Desti- nation 仕	Re- marks 備考
67	3B	K29-0406-13	KNBB ASSY (VOLUME)	UEB	
67	3B	K29-1306-03	KNBB ASSY (VOLUME)	UEB	
67	3A	K29-0407-03	KNBB (TIMER)	UEB	
68	3A	K29-0407-03	KNBB (TIMER)	UEB	
68	3A	K29-1307-03	KNBB (TIMER)	UEB	
68	3A	K29-1307-03	KNBB (TIMER)	UEB	
69	2A	K29-0408-03	KNBB ASSY (SPEAKER, FILTER)	UEB	
69	2A	K29-0408-03	KNBB ASSY (SPEAKER, FILTER)	UEB	
69	2A	K29-1308-03	KNBB ASSY (SPEAKER, FILTER)	UEB	
69	2A	K29-1308-03	KNBB ASSY (SPEAKER, FILTER)	UEB	
70	3A	K29-0409-03	KNBB ASSY (INPUT, MONITOR, G. E.)	UEB	
70	3A	K29-0409-03	KNBB ASSY (INPUT, MONITOR, G. E.)	UEB	
70	3A	K29-1309-03	KNBB ASSY (INPUT, MONITOR, G. E.)	UEB	
70	3A	K29-1309-03	KNBB ASSY (INPUT, MONITOR, G. E.)	UEB	
71	3B	K29-0410-12	KNBB ASSY (TUNER)	UEB	
71	3B	K29-0410-12	KNBB ASSY (TUNER)	UEB	
71	3B	K29-1310-02	KNBB ASSY (TUNER)	UEB	
71	3B	K29-1310-02	KNBB ASSY (TUNER)	UEB	
72	1F	L01-2437-15	POWER TRANSFORMER ASSY	UEB	
72	1F	L01-2437-25	POWER TRANSFORMER ASSY	UEB	
72	1F	L01-2437-25	POWER TRANSFORMER ASSY	UEB	
72	1F	L01-2437-25	POWER TRANSFORMER ASSY	UEB	
73	1F	L01-2441-05	POWER TRANSFORMER ASSY	UEB	
73	1F	L01-2447-05	POWER TRANSFORMER ASSY	UEB	
73	1F	L01-2447-05	POWER TRANSFORMER ASSY	UEB	
74	2D	N09-0128-35	GND TERMINAL	UEB	
74	1B	N09-0406-05	PHILIP SCREW	UEB	
75	3F	N29-0035-05	PUSH RIVET	UEB	
76	2F	N29-0035-05	PUSH RIVET	UEB	
78	2F	R01-4027-05	VARIABLE RESISTOR (PRESET)	UEB	
79	3F	R06-5073-15	VARIABLE RESISTOR (MIC MIX)	UEB	
80	3G	R11-9013-05	VARIABLE RESISTOR (VOLUME)	UEB	
81	1F	S31-2001-05	SLIDE SWITCH (4.5MM-8.5MM)	UEB	
81	1F	S31-2001-05	SLIDE SWITCH (4.5MM-8.5MM)	UEB	
81	1F	S31-2006-05	SLIDE SWITCH (4.5MM-8.5MM)	UEB	
81	1F	S31-2006-05	SLIDE SWITCH (4.5MM-8.5MM)	UEB	
82	1C	T42-0004-05	DC MOTOR	UEB	
83	35	T90-0104-15	LSRP ANTENNA	UEB	
84	1D	T90-0132-05	T TYPE ANTENNA	UEB	
-	-	T90-0132-05	T TYPE ANTENNA	UEB	
-	-	T90-0202-05	T TYPE ANTENNA	UEB	
-	-	T90-0202-05	T TYPE ANTENNA	UEB	
-	-	U09-0D16-05	BATTERY	UEB	
POWER SUPPLY (X00-2160-10)					
C1	2	CCASP14H01J	CERAMIC	UEB	
C1	4	CCASP14H01J	CERAMIC	UEB	
C5	16	CE05FH1070W	ELECTRO	UEB	
C7	16	CE05FH1070W	ELECTRO	UEB	
C9	10	CE04FH1010M	ELECTRO	UEB	

E: Scandinavia & Europe H: Audio Club K: USA
 S: South Africa T: England U: (P) (W) East: Hawaii
 (UE): AMFES(Europe) X: Australia M: Other Areas J: M. U. E. UEB: KR-1000B
 P: Canada Δ indicates safety critical components.

PARTS LIST

* New Parts
 Parts without Parts No. are not supplied.
 Les articles non mentionnés dans le Parts No. ne sont pas fournis.
 Teile ohne Parts No. werden nicht geliefert.

Ref. No. 参照番号	Address 位置	New Parts 新	Parts No. 部品番号	Description 部品名 / 規格	Desti- nation 仕 向	Re- marks 備考
C11 ,12			CE04FW1A221M	ELECTRØ 220UF 10WV		
C13 ,14			CC45SL1H010C	CERAMIC 1PF C		
C15 ,16			CC45SL1H560J	CERAMIC 56PF J		
C17 ,18			CC45SL1H680J	CERAMIC 68PF J		
C19 ,20			CE04W2A010M	ELECTRØ 1UF 100WV		
C21 ,22			CC45FSL1H100D	CERAMIC 10PF D		
C23 ,24			CC45SL1H121J	CERAMIC 120PF J		
C25 ,26			CC45SL1H120J	CERAMIC 12PF J		
C27 ,28			CE04GW1H010M	LL-ELEC 1.0UF 50WV		
C29 ,30			CC45SL1H090D	CERAMIC 9PF D		
C31 ,32			CQ93M2A473M	MYLAR 0.047UF M		
C33 ,34			CQ93M2A103M	MYLAR 0.010UF M		
C35			CE04W1C221M	ELECTRØ 220UF 16WV		
C37			CE04GW1C470M	LL-ELEC 47UF 16WV		
C41 -44			CK45E2H103P	CERAMIC 0.01UF P		
C45 ,46			C90-0560-05	ELECTRØ 8200UF 71WV		
C47 ,48			CE04W2A470M	ELECTRØ 47UF 100WV		
C49			CE04W1C332M	ELECTRØ 3300UF 16WV		
C50 ,51			CK45E1H103P	CERAMIC 0.01UF P		
C52			CE04W1V102M	ELECTRØ 1000UF 35WV		
C53			CE04W1V221M	ELECTRØ 220UF 35WV		
C54			CE04FW1E220M	ELECTRØ 22UF 25WV		
C55			CE04FW1A470M	ELECTRØ 47UF 10WV		
C56			CE04FW1H010M	ELECTRØ 1UF 50WV		
C57			CE04FW1E470M	ELECTRØ 47UF 25WV		
C58			CE04FW1C220M	ELECTRØ 22UF 16WV		
C59 -63			CE04FW1C470M	ELECTRØ 47UF 16WV		
C64 ,65			CK45E1H103P	CERAMIC 0.01UF P		
C66			CE04W1V222M	ELECTRØ 2200UF 35WV		
C67			CE04W1V471M	ELECTRØ 470UF 35WV		
C68			CE04FW1E330M	ELECTRØ 33UF 25WV		
C69			CE04FW1H010M	ELECTRØ 1UF 50WV		
C70			CE04FW1E470M	ELECTRØ 47UF 25WV		
C71			CE04FW1E330M	ELECTRØ 33UF 25WV		
C72			CE04FW1H010M	ELECTRØ 1UF 50WV		
C73			CE04W1E471M	ELECTRØ 470UF 25WV		
C74			CK45FB1H152K	CERAMIC 1500PF K		
C75 ,76			CK45B1H152K	CERAMIC 0.0015UF K		
C101			C91-0699-05	CERAMIC CAPACITØR (TYPE 3)		
-			E11-0089-05	PHONE JACK (PHONES)	KMUH	
-			E11-0089-05	PHONE JACK (PHONES)	UE	
-			E11-0103-05	PHONE JACK (PHONES)	KMU	
-			E11-0103-05	PHONE JACK (PHONES)	EUEB	
△ F1 ,72			F05-5022-05	FUSE (250V 5A)	MUE	
△ F1 ,72			F05-5022-05	FUSE (250V 5A)	UEB	
△ F1 ,72			F05-5022-05	FUSE (250V 5A)	UEB	
△ F1 ,72			F06-5022-05	FUSE (250V 5A)	KK	
△ F1 ,72			F05-4022-05	FUSE (250V 4A)	MUE	
△ F1 ,72			F05-4022-05	FUSE (250V 4A)	UEB	
△ F1 ,72			F05-4022-05	FUSE (250V 4A)	UEB	
△ F1 ,72			F06-4024-05	FUSE (250V 4A)	KK	
-			J13-0041-05	FUSE CLIP		
L1 ,2			L40-1011-03	SMALL FIXED INDUCTØR		

E: Scandinavia & Europe H: Audio Club K: USA P: Canada △ indicates safety critical components.

S: South Africa T: England U: PX(Far East, Hawaii)

UE: AAFES(Europe) X: Australia M: Other Areas K, M, U, E, UE, UE, KR-1000B

PARTS LIST

* New Parts
 Parts without Parts No. are not supplied.
 Les articles non mentionnés dans le Parts No. ne sont pas fournis.
 Teile ohne Parts No. werden nicht geliefert.

Ref. No. 参照番号	Address 位置	New Parts 新	Parts No. 部品番号	Description 部品名/規格	Desti- nation 仕向	Re- marks 備考
L3 ,4			L39-0085-05	PHASE-COMPENSATION COIL		
R21 ,22			RS14GB3A392J	FL-PROOF RS 3.9K J 3A		
R23 ,24			RS14GB3A562J	FL-PROOF RS 5.6K J 3A		
R25 -28			RD14GB2E681J	FL-PROOF RD 680 J 2E		
R31 ,32			RD14GB2E820J	FL-PROOF RD 82 J 2E		
R33 ,34			RS14GB3A103J	FL-PROOF RS 10K J 3A		
R39 -42			RD14GB2E101J	FL-PROOF RD 100 J 2E		
R51 ,52			RS14GB3A100J	FL-PROOF RS 10 J 3A		
R53 ,54			RS14GB3F100J	FL-PROOF RS 10 J 3F		
R55 ,56			RS14GB3A100J	FL-PROOF RS 10 J 3A		
R70			RS14GB3F102J	FL-PROOF RS 1K J 3F		
R80 -82			RS14GB3A180J	FL-PROOF RS 18 J 3A		
R86			RS14GB3D121J	FL-PROOF RS 120 J 3D		
R93			RS14GB3A5R6J	FL-PROOF RS 5.6 J 3A		
R100			RD14GB2E4R7J	FL-PROOF RD 4.7 J 2E		
R102			RD14GB2E4R7J	FL-PROOF RD 4.7 J 2E		
R103			RD14GB2E821J	FL-PROOF RD 820 J 2E		
R104			RD14GB2E4R7J	FL-PROOF RD 4.7 J 2E		
R105			RS14GB3A2R2J	FL-PROOF RS 2.2 J 3A		
R107-109			RS14GB3D201J	FL-PROOF RS 200 J 3D		
R113			RD14GB2E2R2J	FL-PROOF RD 2.2 J 2E		
R115			RS14GB3D271J	FL-PROOF RS 270 J 3D		
R119			RS14GB3A221J	FL-PROOF RS 220 J 3A		
R120			R92-0173-05	RC 2.2M M 2H	KK	
R121,122			RS14GB3A561J	FL-PROOF RS 560 J 3A		
VR1 ,2			R12-0502-05	SEMI FIXED VARIABLE RESISTOR		
△ RL1			S51-1034-05	MAGNETIC RELAY		
RL2			S51-4040-05	MAGNETIC RELAY		
D1 ,2			RD5.1E(B2)	ZENER DIODE		
D3 ,4			RD22E(B2)	ZENER DIODE		
D5 -12			1S2076	DIODE		
D13			W06B	DIODE		
D15			W06B	DIODE		
D17 -20			1S1555	DIODE		
D17 -20			1S2076	DIODE		
D21			M4C-51-13*2	DIODE		
D22 -25			GP200L	DIODE		
D26 -29			W06B	DIODE		
D30			1S2076	DIODE		
D31			RD5.1E(B2)	ZENER DIODE		
D32			RD6.2E(B2)	ZENER DIODE		
D33			RD11E(B2)	ZENER DIODE		
D34			RD15E(B2)	ZENER DIODE		
D35			RB-151LFA	DIODE		
D36			1S2076	DIODE		
Q1 ,2			UPA68H	DUAL FET		
Q3 ,4			2SC945(A)(Q,P)	TRANSISTOR		
Q5 ,6			2SC945(A)(Q,P)	TRANSISTOR		
Q7 ,8			2SC2259(G,H)	DUAL TRANSISTOR		
Q9 ,10			2SA899(B,V)	TRANSISTOR		
Q11 ,12			2SA733(A)(Q,P)	TRANSISTOR		
Q11 ,12			2SA999(E,F)	TRANSISTOR		
Q13 ,14			2SA899(B,V)	TRANSISTOR		

E: Scandinavia & Europe H: Audio Club K: USA P: Canada **△** indicates safety critical components.

S: South Africa T: England U: PX(Far East, Hawaii)

UE: AAFES(Europe) X: Australia M: Other Areas **K, M, U, E, UE**: KR-1000B

PARTS LIST

* New Parts
 Parts without Parts No. are not supplied.
 Les articles non mentionnés dans le Parts No. ne sont pas fournis.
 Teile ohne Parts No. werden nicht geliefert.

Ref. No. 参照番号	Address 位置	New Parts 新	Parts No. 部品番号	Description 部品名 / 規格	Desti- nation 仕 向	Re- marks 備考
Q15 ,16			2SC1904(B,V)	TRANSISTOR		
Q17			2SC945(A)(Q,P)	TRANSISTOR		
Q18			2SA1127NC(R,S)	TRANSISTOR		
Q18			2SA733(A)(Q,P)	TRANSISTOR		
Q18			2SA999(E,F)	TRANSISTOR		
Q19			2SC1841	TRANSISTOR		
Q19			2SC2378(Q,P)	TRANSISTOR		
Q20			2SA954(L,K)	TRANSISTOR		
Q21 ,22			2SC945(A)(Q,P)	TRANSISTOR		
Q23			2SC2003(L,K)	TRANSISTOR		
Q24			2SC945(A)(Q,P)	TRANSISTOR		
Q25			2SC2003(L,K)	TRANSISTOR		
Q26			2SC945(A)(Q,P)	TRANSISTOR		
Q27			2SC2003(L,K)	TRANSISTOR		
Q28			2SA1127NC(R,S)	TRANSISTOR		
Q28			2SA733(A)(Q,P)	TRANSISTOR		
Q28			2SA999(E,F)	TRANSISTOR		
Q29			2SC2003(L,K)	TRANSISTOR		
Q31			2SD330	TRANSISTOR		
Q32 ,33			2SC945(A)(Q,P)	TRANSISTOR		
Q34 -36			2SA954(L,K)	TRANSISTOR		
Q37			2SD330	TRANSISTOR		
Q38 ,39			2SC945(A)(Q,P)	TRANSISTOR		
Q40			2SD330	TRANSISTOR		
Q41 ,42			2SA1127NC(R,S)	TRANSISTOR		
Q41 ,42			2SA733(A)(Q,P)	TRANSISTOR		
Q41 ,42			2SA999(E,F)	TRANSISTOR		
TUNER (X05-2000-10)						
C1			C91-0085-05	CERAMIC	0.022UF	N
C2			CE04FW1C470M	ELECTRO	47UF	16WV
C3			CK45FB1H471K	CERAMIC	470PF	K
C4 ,5			CK45FF1H103Z	CERAMIC	0.01UF	Z
C6 ,7			C91-0085-05	CERAMIC	0.022UF	N
C8			CK45FB1H471K	CERAMIC	470PF	K
C9 ,10			CK45FF1H473Z	CERAMIC	0.047UF	Z
C11			CK45F1H473Z	CERAMIC	0.047UF	Z
C12			CK45FB1H331K	CERAMIC	330PF	K
C13			CE04FW1HR47M	ELECTRO	0.47UF	50WV
C14 -16			C91-0085-05	CERAMIC	0.022UF	N
C17			CE04FW1H010M	ELECTRO	1UF	50WV
C18			C91-0085-05	CERAMIC	0.022UF	N
C19			CE04FW1C101M	ELECTRO	100UF	16WV
C20			C91-0085-05	CERAMIC	0.022UF	N
C21			CE04FW1C100M	ELECTRO	10UF	16WV
C22			CE04W1C471M	ELECTRO	470UF	16WV
C23			CQ93FM1H473K	MYLAR	0.047UF	K
C24			CK45FB1H152K	CERAMIC	1500PF	K
C25			CQ09FS1H102J	POLYSTY	1000PF	J
C26			CQ93FM1H222K	MYLAR	2200PF	K
C27			CE04W1H3R3M	ELECTRO	3.3UF	50WV
C28			CE04FW1HR47M	ELECTRO	0.47UF	50WV
C29 ,30			CE04FW1H010M	ELECTRO	1UF	50WV
C31			CE04FW1H3R3M	ELECTRO	3.3UF	50WV
C32			CQ93FM1H103K	MYLAR	0.01UF	K

E: Scandinavia & Europe H: Audio Club K: USA P: Canada Δ indicates safety critical components.

S: South Africa T: England U: PX(Far East, Hawaii)

UE: AAFES(Europe) X: Australia M: Other Areas K, M, U, E, UEB; KR-1000B

PARTS LIST

* New Parts
 Parts without Parts No. are not supplied.
 Les articles non mentionnés dans le Parts No. ne sont pas fournis.
 Teile ohne Parts No. werden nicht geliefert.

Ref. No. 参照番号	Address 位置	New Parts 新	Parts No. 部品番号	Description 部品名 / 規格	Desti- nation 向	Re- marks 備考
C37 ,38			CE04FW1C100M	ELECTRØ 10UF 16WV		
C39 -42			CE04FW1HR47M	ELECTRØ 0.47UF 50WV		
C43			CC45SL1H271J	CERAMIC 270PF J		
C45			CE04FW1E470M	ELECTRØ 47UF 25WV		
C46			CE04W1E470M	ELECTRØ 47UF 25WV		
C47 -50			CQ93M1H272J	MYLAR 0.0027UF J		
C51 ,52			CQ93FM1H562J	MYLAR 5600PF J		
C53 ,54			CE04FW1C100M	ELECTRØ 10UF 16WV		
C55 ,56			CE04FW1H010M	ELECTRØ 1UF 50WV		
C60			CK45FF1H103Z	CERAMIC 0.01UF Z		
C61			CQ09FS1H391J	POLYSTY 390PF J		
C62			CK45FF1H473Z	CERAMIC 0.047UF Z		
C63			C91-0083-05	CERAMIC 0.01UF N		
C64			CK14D1H102M	CERAMIC 1000PF M		
C65			CK45FF1H473Z	CERAMIC 0.047UF Z		
C66			CQ93FM1H223K	MYLAR 0.022UF K		
C67			CE04FW1C100M	ELECTRØ 10UF 16WV		
C68			C91-0083-05	CERAMIC 0.01UF N		
C69			CQ93M1H223K	MYLAR 0.022UF K		
C70			CQ93FM1H102K	MYLAR 1000PF K		
C71			CQ93M1H103K	MYLAR 0.01UF K		
C72			CE04FW1H010M	ELECTRØ 1UF 50WV		
C73			CE04FW1H3R3M	ELECTRØ 3.3UF 50WV		
C74			CK45F1H103Z	CERAMIC 0.01UF Z		
C75			CQ93M1H104K	MYLAR 0.1UF K		
C76			C91-0083-05	CERAMIC 0.01UF N		
C80			CE04FW1C101M	ELECTRØ 100UF 16WV		
C81			CE04FW1H2R2M	ELECTRØ 2.2UF 50WV		
C83			CE04FW1H010M	ELECTRØ 1UF 50WV		
C85			CK45F1H473Z	CERAMIC 0.047UF Z		
C86			CE04FW1C100M	ELECTRØ 10UF 16WV		
C87			CK45F1H473Z	CERAMIC 0.047UF Z		
C88			CK45FF1H103Z	CERAMIC 0.01UF Z		
C89			CK45B1H102K	CERAMIC 0.001UF K		
C100-102			CE04FW1HR47M	ELECTRØ 0.47UF 50WV		
C104			CE04FW1H4R7M	ELECTRØ 4.7UF 50WV		
C105			CE04FW1V100M	ELECTRØ 10UF 35WV		
C106			CE04FW1H010M	ELECTRØ 1UF 50WV		
C107			CE04FW1A101M	ELECTRØ 100UF 10WV		
C108			CK45FB1H102K	CERAMIC 0.001UF K		
C109			CE04W1C221M	ELECTRØ 220UF 16WV		
C110			CE04FW1E470M	ELECTRØ 47UF 25WV		
C111			CE04FW1V330M	ELECTRØ 33UF 35WV		
C112			C91-0085-05	CERAMIC 0.022UF N		
C201			CK45F1H103Z	CERAMIC 0.01UF Z		
C202,203			CE04W1V100M	ELECTRØ 10UF 35WV		
C204			CK45B1H471K	CERAMIC 470PF K		
C205			CC45SL1H121J	CERAMIC 120PF J		
C206			CE04W1C470M	ELECTRØ 47UF 16WV		
C207			CE04W1C101M	ELECTRØ 100UF 16WV		
C208			CK45F1H103Z	CERAMIC 0.01UF Z		
C209			CC45CH1H101J	CERAMIC 100PF J		
C210			CC45CH1H270J	CERAMIC 27PF J		
C211			CK45F1H103Z	CERAMIC 0.01UF Z		
C212			CE04W1C330M	ELECTRØ 33UF 16WV		

E: Scandinavia & Europe H: Audio Club K: USA P: Canada Δ indicates safety critical components.

S: South Africa T: England U: PX(Far East, Hawaii)

UE: AAFES(Europe) X: Australia M: Other Areas K, M, U, E, UEB; KR-1000B

PARTS LIST

* New Parts
 Parts without Parts No. are not supplied.
 Les articles non mentionnés dans le Parts No. ne sont pas fournis.
 Teile ohne Parts No. werden nicht geliefert.

Ref. No. 参照番号	Address 位置	New Parts 新	Parts No. 部品番号	Description 部品名 / 規格	Desti- nation 仕 向	Re- marks 備考
C213			C91-0083-05	CERAMIC 0.01UF N		
C214-219			CE04W1H010M	ELECTRØ 1UF 50WV		
C220			CK45F1H103Z	CERAMIC 0.01UF Z		
C221			CE04W1E220M	ELECTRØ 22UF 25WV		
C222, 223			CE04W1H010M	ELECTRØ 1UF 50WV		
C225			CE04AW1C101M	LL-ELEC 100UF 16WV		
C226			CE04W1V330M	ELECTRØ 33UF 35WV		
C227			CK45F1H473Z	CERAMIC 0.047UF Z		
C228, 229			CK45F1H103Z	CERAMIC 0.01UF Z		
C230			CC45SL1H220J	CERAMIC 22PF J		
C231			CE04W0J221M	ELECTRØ 220UF 6.3WV		
C232			CK45F1H103Z	CERAMIC 0.01UF Z		
C233, 234			CC45CH1H330J	CERAMIC 33PF J		
C235			CE04W1H010M	ELECTRØ 1UF 50WV		
C236			CE04W1A101M	ELECTRØ 100UF 10WV		
C237			CK45F1H473Z	CERAMIC 0.047UF Z		
C238			CE04BW1H010M	NP-ELEC 1UF 50WV		
C239			CQ93M1H333K	MYLAR 0.033UF K		
C241			CE04W1V221M	ELECTRØ 220UF 35WV		
C242			CK45F1H103Z	CERAMIC 0.01UF Z		
C243			CE04BW1H010M	NP-ELEC 1UF 50WV		
C244, 245			CK45B1H102K	CERAMIC 0.001UF K		
C246			CE04W1V330M	ELECTRØ 33UF 35WV		
C247			CE04W1H010M	ELECTRØ 1UF 50WV		
C250			CE04W1E470M	ELECTRØ 47UF 25WV		
C251			CK45F1H473Z	CERAMIC 0.047UF Z		
C252			CE04W1E101M	ELECTRØ 100UF 25WV		
C253, 254			CK45F1H473Z	CERAMIC 0.047UF Z		
C255			CE04W1A101M	ELECTRØ 100UF 10WV		
C256-258			CK45F1H473Z	CERAMIC 0.047UF Z		
C259			CE04W1E470M	ELECTRØ 47UF 25WV		
C260			CE04W1C330M	ELECTRØ 33UF 16WV		
C262			CK45F1H473Z	CERAMIC 0.047UF Z		
C267			CE04W1C101M	ELECTRØ 100UF 16WV		
C268			CK45B1H102K	CERAMIC 0.001UF K		
C270			CC45SL1H150J	CERAMIC 15PF J		
TC1 ,2			C05-0303-05	CERAMIC TRIMMER CAPACITOR		
202	2D		E20-0439-05	TERMINAL BOARD (ANTENNA)		
CF1			L19-0026-05	BALUN TRANSFORMER		
CF2 ,3			L72-0125-05	CERAMIC FILTER		
CF4 ,5			L72-0115-05	CERAMIC FILTER		
CF6			L72-0135-05	CERAMIC FILTER		
CF7			L72-0097-05	CERAMIC FILTER		
L1			L72-0096-05	CERAMIC FILTER		
L2			L30-0327-15	FM IFT		
L3 ,4			L30-0328-05	FM IFT		
L5			L79-0060-05	LC FILTER		
L6			L31-0455-05	MW-RF COIL		
L7			L32-0258-05	MW OSCILLATING COIL		
L10			L30-0337-05	AM IFT		
L12 -19			L40-1021-03	SMALL FIXED INDUCTOR		
X1			L40-1021-12	SMALL FIXED INDUCTOR		
			L77-0573-05	CRYSTAL RESONATOR		

E: Scandinavia & Europe H: Audio Club K: USA P: Canada Δ indicates safety critical components.

S: South Africa T: England U: PX (Far East, Hawaii)

UE: AAFES (Europe) X: Australia M: Other Areas K, M, U, E, UE; KR-1000B

PARTS LIST

* New Parts
 Parts without Parts No. are not supplied.
 Les articles non mentionnés dans le Parts No. ne sont pas fournis.
 Teile ohne Parts No. werden nicht geliefert.

Ref. No. 参照番号	Address 位置	New Parts 新	Parts No. 部品番号	Description 部品名 / 规格	Desti- nation 仕向	Re- marks 備考
X2 X3			L77-0584-05 L78-0202-05	CRYSTAL RESONATOR RESONATOR		
CP1 ,2 CP3 CP4 CP5 ,6 CP7 ,8			R90-0154-05 R90-0155-05 R90-0156-05 R90-0157-05 R90-0158-05	MULTI-COMP 820K X4 MULTI-COMP 13K X4 MULTI-COMP MULTI-COMP 47K X5 MULTI-COMP 47K X7		
CP9 CP10 CP11 CP12 CP13			R90-0132-05 R90-0160-05 R90-0161-05 R90-0162-05 R90-0163-05	MULTI-COMP 100K X7 MULTI-COMP 820K X8 MULTI-COMP 100K X8 MULTI-COMP 47K X8 MULTI-COMP 47K X9		
CP14 CP15-22 CP23 CP24 CP25-28			R90-0164-05 R90-0168-05 R90-0165-05 R90-0167-05 R90-0166-05	MULTI-COMP MULTI-COMP MULTI-COMP MULTI-COMP MULTI-COMP		
CP30 R6 R14 R28 R30			R90-0188-05 RD14GB2E101J RD14GB2E101J RD14GB2E101J RD14GB2E101J	MULTI-COMP 0.01UF X4 FL-PROOF RD 100 J 2E FL-PROOF RD 100 J 2E FL-PROOF RD 100 J 2E FL-PROOF RD 100 J 2E		
R47 ,48 R73 R86 R146 R147			RD14GB2E101J RD14GB2E101J RD14GB2E560J RD14GB2E101J RD14GB2E100J	FL-PROOF RD 100 J 2E FL-PROOF RD 100 J 2E FL-PROOF RD 56 J 2E FL-PROOF RD 100 J 2E FL-PROOF RD 10 J 2E		
R215 R219 R277,278 R287 R291			RD14GB2E100J RCD5GF2H685M RD14GB2E561J RD14GB2E221J RD14GB2E100J	FL-PROOF RD 10 J 2E RC 6.8M M 2H FL-PROOF RD 560 J 2E FL-PROOF RD 220 J 2E FL-PROOF RD 10 J 2E		
VR3 VR4 VR5 VR6 VR7			R12-1041-05 R12-5030-05 R12-3051-05 R12-3046-05 R12-1040-05	SEMI FIXED VARIABLE RESISTOR SEMI FIXED VARIABLE RESISTOR SEMI FIXED VARIABLE RESISTOR SEMI FIXED VARIABLE RESISTOR SEMI FIXED VARIABLE RESISTOR		
S1			S31-4012-05	SLIDE SWITCH		
D1 -6 D8 -21 D22 D22 D23 -25			1S2076 1S2076 1S1555 1S2076 1S2076	DIODE DIODE DIODE DIODE DIODE		
D26 D27 ,28 D29 D30 D30			KV1236(Z1) 1S2076 RD6.2E(B2) 1S1555 1S2076	VARIABLE CAPACITANCE DIODE DIODE ZENER DIODE DIODE DIODE		
D31 -48 D49 D50 -63 D64 ,65 D67 -71			1S2076 RDB.2E(B2) 1S2076 1N60 1S2076	DIODE ZENER DIODE DIODE DIODE DIODE		

E: Scandinavia & Europe H: Audio Club K: USA P: Canada Δ indicates safety critical components.

S: South Africa T: England U: PX(Far East, Hawaii)

UE: AAFES(Europe) X: Australia M: Other Areas K, M, U, E, UEB; KR-1000B

PARTS LIST

* New Parts
 Parts without Parts No. are not supplied.
 Les articles non mentionnés dans le Parts No. ne sont pas fournis.
 Teile ohne Parts No. werden nicht geliefert.

Ref. No. 参照番号	Address 位置	New Parts 新	Parts No. 部品番号	Description 部品名/規格	Desti- nation 仕向	Re- marks 備考
D80 -84			1S2076	DIODE		
D85 -87			1S1555	DIODE		
D85 -87			1S2076	DIODE		
D88 ,89			1S2076	DIODE		
D98			1N60	DIODE		
D99			1S1555	DIODE		
D99			1S2076	DIODE		
FL1			FIP13AM10	FLUORESCENT INDICATOR TUBE		
IC1			HA11225	IC		
IC2			HA11223W	IC		
IC3			AN6552	IC		
IC3			UPC4557C	IC		
IC4			MB84069BM	IC		
IC4			TC4069UBP	IC		
IC4			UPD4069UBC	IC		
IC5			LA1245	IC		
IC6			MB74LS42M	IC		
IC7			UPD553C-127	IC		
IC8			MB84020BM	IC		
IC8			TC4020BP	IC		
IC8			UPD4020C	IC		
IC9			MC14042UBCP	IC		
IC9			UPD4042C	IC		
IC10			MB84069BM	IC		
IC10			TC4069UBP	IC		
IC10			UPD4069UBC	IC		
IC11			UPD1703C-016	IC		
IC12			UPB553AC	IC		
IC13			MS1903L	IC		
IC14			AN6552	IC		
IC14			UPC4557C	IC		
Q1			2SC1923	TRANSISTOR		
Q2			2SA733(A) (Q,P)	TRANSISTOR		
Q3 -5			2SK105(H,J)	FET		
Q7 -14			2SC945(A) (Q,P)	TRANSISTOR		
Q15 ,16			2SA733(A) (Q,P)	TRANSISTOR		
Q17			2SC945(A) (Q,P)	TRANSISTOR		
Q18 ,19			2SC1735	TRANSISTOR		
Q21 -27			2SA733(A) (Q,P)	TRANSISTOR		
Q28			2SK105(H,J)	FET		
Q29			2SA733(A) (Q,P)	TRANSISTOR		
Q30			2SD863	TRANSISTOR		
Q31			2SC945(A) (Q,P)	TRANSISTOR		
Q32 ,33			2SA733(A) (Q,P)	TRANSISTOR		
Q34 -39			2SD863	TRANSISTOR		
Q40 -45			2SA733(A) (Q,P)	TRANSISTOR		
Q46 ,47			2SC945(A) (Q,P)	TRANSISTOR		
Q48			2SA733(A) (Q,P)	TRANSISTOR		
Q49			2SA733(A) (Q,P)	TRANSISTOR		
Q50 ,51			2SC945(A) (Q,P)	TRANSISTOR		
Q52 -67			2SA733(A) (Q,P)	TRANSISTOR		
Q71 -75			2SA733(A) (Q,P)	TRANSISTOR		
Q81 -87			2SC945(A) (Q,P)	TRANSISTOR		
Q88 ,89			2SA733(A) (Q,P)	TRANSISTOR		
Q90			2SC945(A) (Q,P)	TRANSISTOR		

E: Scandinavia & Europe H: Audio Club K: USA P: Canada Δ indicates safety critical components.
 S: South Africa T: England U: PX(Far East, Hawaii)
 [UE]: AAFES(Europe) X: Australia M: Other Areas K, M, U, E, UE; KR-1000B

PARTS LIST

* New Parts
 Parts without Parts No. are not supplied.
 Les articles non mentionnés dans le Parts No. ne sont pas fournis.
 Teile ohne Parts No. werden nicht geliefert.

Ref. No. 参照番号	Address 位置	New Parts 新	Parts No. 部品番号	Description 部品名 / 規格	Desti- nation 仕向	Re- marks 備考
Q91 -96 Q97 Q98			2SA733(A)(Q,P) 2SK105(H,J) 2SC945(A)(Q,P)	TRANSISTOR FET TRANSISTOR		
-			WD2-0070-05	FM FRONT-END ASSY		
MAIN AMP (X07-1900-10)						
C1 ,2 C3 -6 C7 -10			CE04FW1A470M CQ93FM1H153K CE04FW1V100M	ELECTRO 47UF 10WV MYLAR 0.015UF K ELECTRO 10UF 35WV		
R1 ,2 R3 ,4 R5 ,6 R7 -10 R15 -18			RD14GB2E680J RD14GB2E270J RD14GB2E560J RD14GB2E390J RD14GB2E470J	FL-PROOF RD 68 J 2E FL-PROOF RD 27 J 2E FL-PROOF RD 56 J 2E FL-PROOF RD 39 J 2E FL-PROOF RD 47 J 2E		
R19 -26 R27 -34 R35 -38 VR1 ,2			RD14GB2E4R7J R92-0166-05 R92-0167-05 R12-0077-05	FL-PROOF RD 4.7 J 2E METAL-PLATE 0.22 K 3D METAL-PLATE 0.22 K 3H SEMI FIXED VARIABLE RESISTOR		
D1 ,2 D1 ,2 D3 -14 D15 ,16 Q1 ,2			1S1555 1S2076 1S2076A STV-3H(G) 2SC2591*1(Q,R)	DIODE DIODE DIODE VARISTOR TRANSISTOR		
Q3 ,4 Q5 -8 Q9 -12 Q13 ,14 Q13 ,14			2SA1111*1(Q,R) 2SA1186(O,Y) 2SC2837(O,Y) 2SC2320(E,F) 2SC828A(Q,R)	TRANSISTOR TRANSISTOR TRANSISTOR TRANSISTOR TRANSISTOR		
Q13 ,14 Q15 -18 Q15 -18 Q19 ,20 Q19 ,20			2SC945(A)(Q,P) 2SA733(A)(Q,P) 2SA999(E,F) 2SC2320(E,F) 2SC828A(Q,R)	TRANSISTOR TRANSISTOR TRANSISTOR TRANSISTOR TRANSISTOR		
Q19 ,20			2SC945(A)(Q,P)	TRANSISTOR		
PRE AMP (X08-1870-10)						
C1 ,2 C3 ,4 C5 ,6 C7 ,8 C9 ,10			CC45FSL1H221J CE04FW1A221M CC45SL1H560J CQ93M1H113J CQ93M1H393J	CERAMIC 220PF J ELECTRO 220UF 10WV CERAMIC 56PF J MYLAR 0.011UF J MYLAR 0.039UF J		
C11 ,12 C13 ,14 C15 ,16 C17 ,18 C19 ,20			CE04FW1A101M CE04FW1C330M CE04AW1E4R7M CE04FW1H010M CE04FW1A220M	ELECTRO 100UF 10WV ELECTRO 33UF 16WV LL-ELEC 4.7UF 25WV ELECTRO 1UF 50WV ELECTRO 22UF 10WV		
C21 ,22 C23 C24 C25 C26 ,27			CE04FW1C100M CE04FW1E101M CE04W1C471M CE04FW1A101M CK45FB1H102K	ELECTRO 10UF 16WV ELECTRO 100UF 25WV ELECTRO 470UF 16WV ELECTRO 100UF 10WV CERAMIC 0.001UF K		
C28 C29 ,30 C31 ,32 C33			CE04FW1V100M CK45B1H821K CE04AW1H010M CE04FW1A221M	ELECTRO 10UF 35WV CERAMIC 820PF K LL-ELEC 1UF 50WV ELECTRO 220UF 10WV		

E: Scandinavia & Europe H: Audio Club K: USA P: Canada Δ indicates safety critical components.

S: South Africa T: England U: PX(Far East, Hawaii)

UE: AAFES(Europe) X: Australia M: Other Areas K, M, U, E, UEB: KR-1000B

PARTS LIST

* New Parts
 Parts without Parts No. are not supplied.
 Les articles non mentionnés dans le Parts No. ne sont pas fournis.
 Teile ohne Parts No. werden nicht geliefert.

Ref. No. 参照番号	Address 位置	New Parts 新	Parts No. 部品番号	Description 部品名/規格	Desti- nation 仕向	Re- marks 備考
R25 -28			RD14GB2E330J	FL-PROOF RD 33	J 2E	
R53			RS14GB3A682J	FL-PROOF RS 6.8K	J 3A	
R55			RD14GB2E560J	FL-PROOF RD 56	J 2E	
R56			RD14GB2E101J	FL-PROOF RD 100	J 2E	
R61			RD14GB2E100J	FL-PROOF RD 10	J 2E	KK
D1 -15			1S1555	DIODE		
D1 -15			1S2076	DIODE		
D16			RDB. 2E(B2)	ZENER DIODE		
D17			RD16E(B3)	ZENER DIODE		
Q1 -4			2SK163(L,M)	FET		
Q5 ,6			2SA733(A)(Q,P)	TRANSISTOR		
Q5 ,6			2SA999(E,F)	TRANSISTOR		
Q7 ,8			2SA992(F,E)	TRANSISTOR		
Q9 ,10			2SC232D(E,F)	TRANSISTOR		
Q9 ,10			2SC828A(Q,R)	TRANSISTOR		
Q9 ,10			2SC945(A)(Q,P)	TRANSISTOR		
Q11 ,12			2SA733(A)(Q,P)	TRANSISTOR		
Q11 ,12			2SA999(E,F)	TRANSISTOR		
Q13 ,14			2SD655	TRANSISTOR		
Q15 -17			2SC232D(E,F)	TRANSISTOR		
Q15 -17			2SC828A(Q,R)	TRANSISTOR		
Q15 -17			2SC945(A)(Q,P)	TRANSISTOR		
Q18			2SA733(A)(Q,P)	TRANSISTOR		
Q18			2SA999(E,F)	TRANSISTOR		
Q19			2SC2003(L,K)	TRANSISTOR		
Q20			2SC232D(E,F)	TRANSISTOR		
Q20			2SC828A(Q,R)	TRANSISTOR		
Q20			2SC945(A)(Q,P)	TRANSISTOR		
Q21			2SA954(L,K)	TRANSISTOR		
TONE AMP (X11-1670-10)						
C1 ,2			CE04GW1H2R2M	LL-ELEC 2.2UF	50WV	
C3 ,4			CE04GW1E4R7M	LL-ELEC 4.7UF	25WV	
C5 ,6			CC45FSL1H220J	CERAMIC 22PF	J	
C7 ,8			CE04GW1E4R7M	LL-ELEC 4.7UF	25WV	
C9 ,10			CQ93FM1H152J	MYLAR 1500PF	J	
C11 ,12			CE04GW1H010M	LL-ELEC 1.0UF	50WV	
C13 ,14			CQ93FM1H183J	MYLAR 0.018UF	J	
C15 ,16			CE04GW1HR33M	LL-ELEC 0.33UF	50WV	
C17 ,18			CQ93FM1H822J	MYLAR 8200PF	J	
C19 ,20			CQ93M1H154J	MYLAR 0.15UF	J	
C21 ,22			CQ93FM1H332J	MYLAR 0.0033UF	J	
C23 ,24			CQ93FM1H473J	MYLAR 0.047UF	J	
C25 ,26			CQ93FM1H152J	MYLAR 1500PF	J	
C27 ,28			CQ93FM1H223J	MYLAR 0.022UF	J	
C29 ,30			CC45FSL1H471J	CERAMIC 470PF	J	
C31 ,32			CQ93FM1H822J	MYLAR 8200PF	J	
C33 ,34			CC45FSL1H221J	CERAMIC 220PF	J	
C35 ,36			CQ93FM1H332J	MYLAR 0.0033UF	J	
C37 ,38			CC45FSL1H101J	CERAMIC 100PF	J	
C39			CE04GW1H010M	LL-ELEC 1.0UF	50WV	
C40			CK45FB1H331K	CERAMIC 330PF	K	
C41			CE04FW1H010M	ELECTRO 1UF	50WV	
C42			CC45FSL1H101J	CERAMIC 100PF	J	
C45			CE04GW1H2R2M	LL-ELEC 2.2UF	50WV	
C46 ,47			CE04FW1E100M	ELECTRO 10UF	25WV	

E: Scandinavia & Europe H: Audio Club K: USA P: Canada indicates safety critical components.

S: South Africa T: England U: PX(Far East, Hawaii)

UE: AAFES(Europe) X: Australia M: Other Areas K, M, U, E, UE: KR-1000B

PARTS LIST

* New Parts
 Parts without Parts No. are not supplied.
 Les articles non mentionnés dans le Parts No. ne sont pas fournis.
 Teile ohne Parts No. werden nicht geliefert.

Ref. No. 参照番号	Address 位置	New Parts 新	Parts No. 部品番号	Description 部品名 / 規格	Desti- nation 仕向	Re- marks 備考
C48 ,49			CE04FW1E101M	ELECTRØ 100UF 25WV		
C51 ,52			CE04BW1E2R2M	NP-ELEC 2.2UF 25WV		
C53 -55			CE04FW1H2R2M	ELECTRØ 2.2UF 50WV		
C56			CE04W1E220M	ELECTRØ 22UF 25WV		
C57 ,58			CE04W1H2R2M	ELECTRØ 2.2UF 50WV		
C59 -62			CE04FW1H010M	ELECTRØ 1UF 50WV		
C63 ,64			CE04FW1C100M	ELECTRØ 10UF 16WV		
C65 ,66			CE04FW1E101M	ELECTRØ 100UF 25WV		
C67			CE04W1V101M	ELECTRØ 100UF 35WV		
R81 ,82			RD14GB2E471J	FL-PRØØF RD 470 J 2E		
R83 ,84			RD14GB2E560J	FL-PRØØF RD 56 J 2E		
R131			RS14GB3A180J	FL-PRØØF RS 18 J 3A		
R133			RD14GB2E101J	FL-PRØØF RD 100 J 2E		
R134			RD14GB2E470J	FL-PRØØF RD 47 J 2E		
VR1 -7			R29-3004-05	VARIABLE RESISTØR (PUSH TYPE)		
VR11,12			R12-3302-05	SEMI FIXED VARIABLE RESISTØR		
VR13,14			R12-2302-05	SEMI FIXED VARIABLE RESISTØR		
D1 ,2			RD8.2E(B2)	ZENER DIØDE		
D3 -7			1S1555	DIØDE		
D3 -7			1S2076	DIØDE		
D11 -16			1S1555	DIØDE		
D11 -16			1S2076	DIØDE		
D17 -20			1N60	DIØDE		
D21 -23			1S1555	DIØDE		
D21 -23			1S2076	DIØDE		
FL1			FIP24A15YS	FLUØRESCENT INDICATOR TUBE		
IC1 ,2			AN6551	IC		
IC3			MB84066BM	IC		
IC4 ,5			BA65B	IC		
Q1 -16			2SC1845(F,E)	TRANSISTØR		
Q1 -16			2SC1980(S,T)	TRANSISTØR		
Q17			2SC2320(E,F)	TRANSISTØR		
Q17			2SC828A(Q,R)	TRANSISTØR		
Q17			2SC945(A)(Q,P)	TRANSISTØR		
Q18			2SA733(A)(Q,P)	TRANSISTØR		
Q18			2SA999(E,F)	TRANSISTØR		
Q21 -24			2SC2320(E,F)	TRANSISTØR		
Q21 -24			2SC828A(Q,R)	TRANSISTØR		
Q21 -24			2SC945(A)(Q,P)	TRANSISTØR		
Q25			2SA733(A)(Q,P)	TRANSISTØR		
Q25			2SA999(E,F)	TRANSISTØR		
Q26 ,27			2SK105(H,J)	FET		
Q28			2SA733(A)(Q,P)	TRANSISTØR		
Q28			2SA999(E,F)	TRANSISTØR		
Q29			2SC2003(L,K)	TRANSISTØR		
Q30			2SC2320(E,F)	TRANSISTØR		
Q30			2SC828A(Q,R)	TRANSISTØR		
Q30			2SC945(A)(Q,P)	TRANSISTØR		
SPEAKER (X13-3150-10)						
C1 ,2			CK45F1H103Z	CERAMIC D. 01UF Z		
4D1	1C		E20-0812-05	TERMINAL BOARD(SPEAKERS)		
RL1			SS1-2049-05	MAGNETIC RELAY		

E: Scandinavia & Europe H: Audio Club K: USA P: Canada Δ indicates safety critical components.

S: South Africa T: England U: PX(Far East Hawaii)

UE: AAFES(Europe) X: Australia M: Other Areas K, M, U, E, UE; KR-1000B

PARTS LIST

* New Parts
Parts without Parts No. are not supplied.
Les articles sans numéros de pièces ne sont pas fournis.
Teile ohne Parts No. werden nicht geliefert.

Ref. No. 参照番号	Address 位置	Parts No. 部品番号	Description 部品名/規格	Desti- nation 仕	Re- marks 備考
RL2 RL4		SS1-2048-05 SS1-2049-05	MAGNETIC RELAY		
D1 -3		M06B	DIBDE		
PL1 -21		B30-0298-05	LAMP		
C1 -2		C093FM1H32K	MYLAR		
C3 -4		CED04FM1H22M	LL-ELEC		
C5 -6		C093FM1H273K	MYLAR		
C7 -10		CED04FM1H010M	ELECTR8		
C15		CED04FM1C100M	LL-ELEC		
C16 -17		CED04FM1C100M	ELECTR8		
C20 -23		CK45FF1H413Z	CERAMIC		
-		E06-0513-05	REC/PLAY JACK		
-		E13-0618-05	PHONE JACK		
R79 -80		RS14GB3A470J	FL-PR08F RS 47		J 3A
R100-101		RC05GF2H471K	RC		K 2H
VR1		R06-5074-15	VARIABLE RESISTOR(BALANCE)		
RL1		SS1-2050-05	REED RELAY		
D1 -2		1N60	D18DE		
D3 -4		1S2076	D18DE		
D5 -6		1N60	D18DE		
D7 -17		1S2076	D18DE		
D18		1N60	D18DE		
D19		1S2076	D18DE		
D20		1N60	D18DE		
D21 -43		1S2076	D18DE		
D44		R06-2E(B2)	ZENER D18DE		
D45		R04-1E(B2)	ZENER D18DE		
D46 -56		1S2076	D18DE		
D56 -61		R06-2E(B3)	ZENER D18DE		
D62		1S2076	D18DE		
D63 -70		1S2076	ZENER D18DE		
D71 -77		1S1555	D18DE		
D71 -77		1S2076	D18DE		
IC1		HD14052BP	IC		
IC2		MB840668M	IC		
IC3		MB840528M	IC		
IC3		TC4052UBP	IC		
IC4		UPD4052BC	IC		
IC4		TC4555UBP	IC		
IC4		UPD4553RC	IC		
IC5 -9		MB840668M	IC		
IC10		MB840698M	IC		
IC10		TC4069URP	IC		
IC10		UPD4069UBC	IC		
IC11-13		MB840668M	IC		
IC14		AN6552	IC		
IC14		WPC4557C	IC		
01 -33		2SC2320(E.F)	TRANSISTOR		
01 -33		2SC228A(D.R)	TRANSISTOR		

E: Scandinavia & Europe R: Auto Club K: USA P: Canada
S: South Africa T: England U: PRC(Far East, Hawaii)
[E]: AMES(Europe) X: Australia M: Other Areas B: M. U. J. E. WEB: KR-1000B

PARTS LIST

* New Parts
Parts without Parts No. are not supplied.
Les articles sans numéros de pièces ne sont pas fournis.
Teile ohne Parts No. werden nicht geliefert.

Ref. No. 参照番号	Address 位置	Parts No. 部品番号	Description 部品名/規格	Desti- nation 仕	Re- marks 備考
D1 -33		2SC945(A)(Q.P)	TRANSISTOR		
D34 -3B		28A733(A)(Q.P)	TRANSISTOR		
D34 -3B		28A999(E.F)	TRANSISTOR		
D39		2SC2320(E.F)	TRANSISTOR		
D39		2SC228A(D.R)	TRANSISTOR		
D39 +41		2SC945(A)(Q.P)	TRANSISTOR		
D40 +41		28A999(E.F)	TRANSISTOR		
D42 +65		28K105(H.J)	FET		
D44 -65		2SD592NC	TRANSISTOR		
D44 -65		2SD863	TRANSISTOR		
D66		2SD33D	TRANSISTOR		
D67		2SD313V-AL	TRANSISTOR		
D68		28S514	TRANSISTOR		
D69		28R764	TRANSISTOR		
FL1 -6		B30-0300-05	LAMP		
S1 -57		S40-1033-05	PUSH SWITCH		
S58 -62		S40-2111-05	PUSH SWITCH		
D1		1S1555	D18DE		
D2		1S2076	D18DE		
D2 -4		1S2076	D18DE		
D2 -4		1S1555	D18DE		
D10		1S1555	D18DE		
D10		1S2076	D18DE		
C1		CE04FM1H010M	ELECTR8		
C1		CE04FM1H010M	ELECTR8		
C2		C093FM1H103J	MYLAR		
C2		C093FM1H103J	MYLAR		
C3		C093FM1H223J	MYLAR		
C3		C093FM1H223J	MYLAR		
C4		CED04FM1E220M	NP-ELEC		
C4		CED04FM1H010M	NP-ELEC		
C5		CK45FF1H103Z	CERAMIC		
C5		CK45FF1H103Z	CERAMIC		
C7		CE04FM1E220M	ELECTR8		
C7		CE04FM1E220M	ELECTR8		
C8		CK45FF1H103Z	CERAMIC		
C8		CK45FF1H103Z	CERAMIC		
C9		CE04FM1H010M	ELECTR8		
C9		CE04FM1H010M	ELECTR8		
L1		L40-1011-46	SMALL FIXED INDUCTOR		
L1		L40-1011-46	SMALL FIXED INDUCTOR		
BZ1		T95-0016-05	PIEZOELECTRIC VIBRATOR		
BZ1		T95-0016-05	PIEZOELECTRIC VIBRATOR		
D1 -12		1S1555	D18DE		
D1 -12		1S1555	D18DE		
D1 -12		1S2076	D18DE		
D1 -12		1S2076	D18DE		
IC1		TC4011BP	IC		

E: Scandinavia & Europe R: Auto Club K: USA P: Canada
S: South Africa T: England U: PRC(Far East, Hawaii)
[E]: AMES(Europe) X: Australia M: Other Areas B: M. U. J. E. WEB: KR-1000B

KR-1000/B KR-1000/B

PARTS LIST

* New Parts
 Parts without Parts No. are not supplied.
 Les articles non mentionnés dans le Parts No. ne sont pas fournis.
 Teile ohne Parts No. werden nicht geliefert.

Ref. No. 参照番号	Address 位置	Parts No. 部品番号	Description 部品名 / 規格	Designation 仕	Remarks 備考
IC1		TC4011BP	IC	E	
IC1		UPD4011BC	IC	E	
Q1		2SA733(A)(G,P)	TRANSISTOR	E	
Q1		2SA733(A)(G,P)	TRANSISTOR	E	
Q1		2SA999(E,F)	TRANSISTOR	K	
Q2		2SA732(G,P)	TRANSISTOR	E	
Q2		2SC2320(E,F)	TRANSISTOR	E	
Q2		2SC945(A)(G,P)	TRANSISTOR	E	
Q2		2SC945(A)(G,P)	TRANSISTOR	E	

E: Scandinavia & Europe H: Audio Club K: U.S.A.
 S: South Africa T: England U: PX (For East, Hawaii)
 UE: AMES (Europe) X: Australia M: Other Areas P: Canada
 △ Indicates safety critical components.

WORLD MAP & AREA CODE

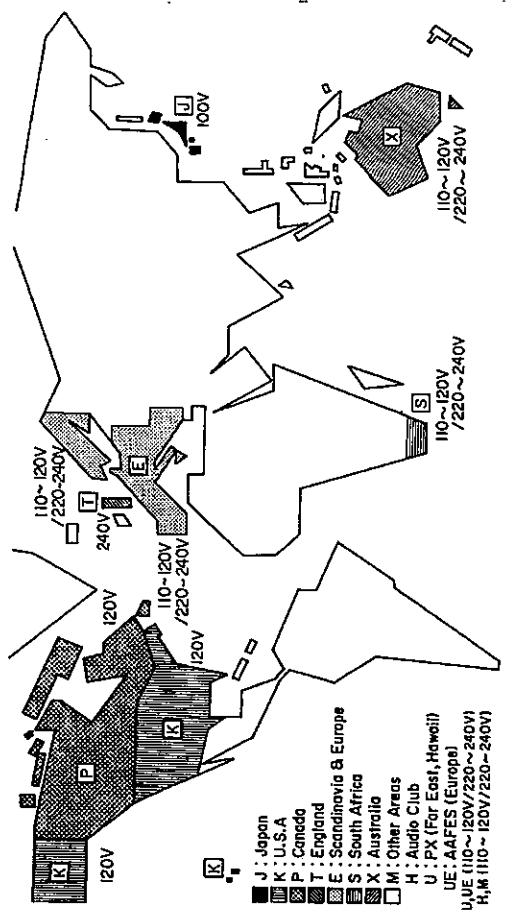

Notes:
 Component and circuitry are subject to modification to insure best operation under differing local conditions. This manual is based on the U.S. (K) standard, and provides information on regional circuit modification through use of alternate schematic diagrams, and information on regional component variations through use of parts list.

TRIO-KENWOOD CORPORATION
 Shorogi Shibuya Building, 17-5, 2-chome Shibuya, Shibuya-ku, Tokyo 150, Japan
KENWOOD ELECTRONICS
 1315 E. Market Street, Suite 100, San Mateo, California 94402, U.S.A.
 75 Seawanh Drive, Secaucus, New Jersey 07094, U.S.A.
TRIO-KENWOOD CANADA INC.
 1070, Jackson Court, Mississauga, Ontario, Canada L4W 2V5
TRIO-KENWOOD ELECTRONICS NV
 Leuvensteeweg 50A B-1930 Zaventem, Belgium
TRIO-KENWOOD ELECTRONICS GmbH
 Rudolf-Brass-Str. 20, 6056 Henselstramm, West Germany
TRIO-KENWOOD FRANCE S.A.
 5, Boulevard Ney, 75018 Paris, France
TRIO-KENWOOD (AUSTRALIA) PTY. LTD. (INCORPORATED IN AUSTRALIA)
 4E, Woodcock Place, Lane Cove, N.S.W. 2066, Australia
KENWOOD & LEE ELECTRONICS, LTD.
 Wang Kee Building, 5th Floor, 34-37, Connaught Road, Central, Hong Kong

© 1983-9 PRINTED IN JAPAN BS1-1230-10 (TI) 2702